

# MOHAWK MP-18 SERIES 24 VOLT BATTERY OPERATED MOBILE LIFT DATA SHEET:

## TIRE DIMENSIONS

ENTER DIMENSION FOR LARGEST AND SMALLEST TIRES:

	DIM. 'A'	DIM. 'B'	DIM. 'W'	TIRE SIZE
LARGEST				
SMALLEST				

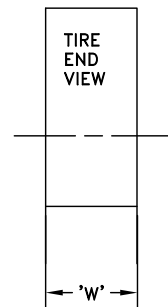
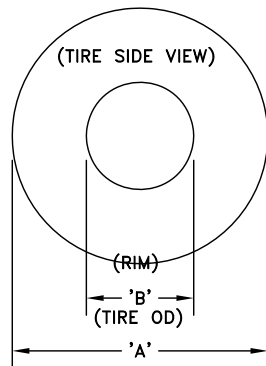

### 1. SELECT LIFT MODEL BELOW:

MODEL NAME	LIFT CAP (LBS)	FORK LENGTH ON POST							
		1	2	3	4	5	6	7	8
MP-18-505	36,000	15"	15"						
MP-18-513	32,000	22"	22"						
MP-18-506	72,000	15"	15"	15"	15"				
MP-18-530	68,000	15"	15"	22"	22"				
MP-18-514	64,000	22"	22"	22"	22"				
MP-18-507	108,000	15"	15"	15"	15"	15"	15"		
MP-18-558	104,000	15"	15"	15"	15"	22"	22"		
MP-18-559	100,000	15"	15"	22"	22"	22"	22"		
MP-18-515	96,000	22"	22"	22"	22"	22"	22"		
MP-18-508	144,000	15"	15"	15"	15"	15"	15"	15"	15"
MP-18-560	140,000	15"	15"	15"	15"	15"	15"	22"	22"
MP-18-561	136,000	15"	15"	15"	15"	22"	22"	22"	22"
MP-18-562	132,000	15"	15"	22"	22"	22"	22"	22"	22"
MP-18-516	128,000	22"	22"	22"	22"	22"	22"	22"	22"

### MP-18 (24 VDC) SERIES POST SPECIFICATIONS:

CAPACITY: 18,000 LB EACH  
 STROKE: 67 INCHES  
 LIFTING SPEED: 45 SECONDS EMPTY, 144 SECONDS AT FULL LOAD CAPACITY. LIFT SPEED VARIES WITH WEIGHT.  
 POWER REQUIRED: 120 VAC, 4 AMPS PER POST (FOR CHARGER)  
 BATTERY SPEC: (2) 12 VDC DEEP CYCLE SEALED - MAINTENANCE FREE  
 POST QUANTITY: 2, 4, 6 OR 8  
 MAX TIRE SIZE: 48 INCH DIA  
 FORK LENGTH: 15 INCH  
 FORK WIDTH: 11 1/2 INCH MIN, 24 1/4 MAX  
 LOCK POSITIONS: 3" INTERVALS STARTING @ 12"

**24 VDC BATTERY OPERATED LIFT**

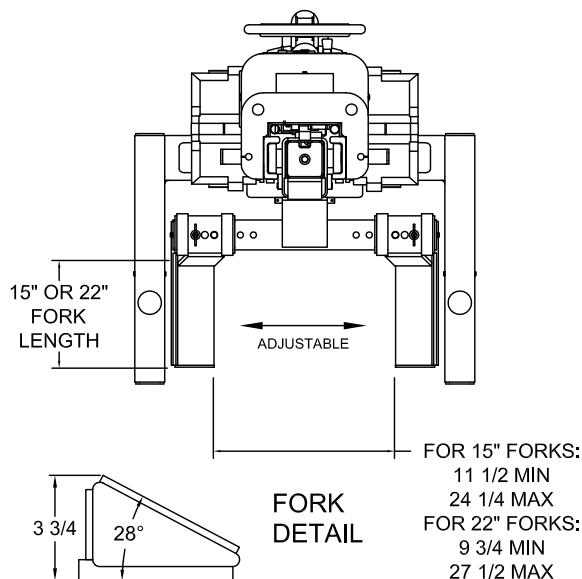
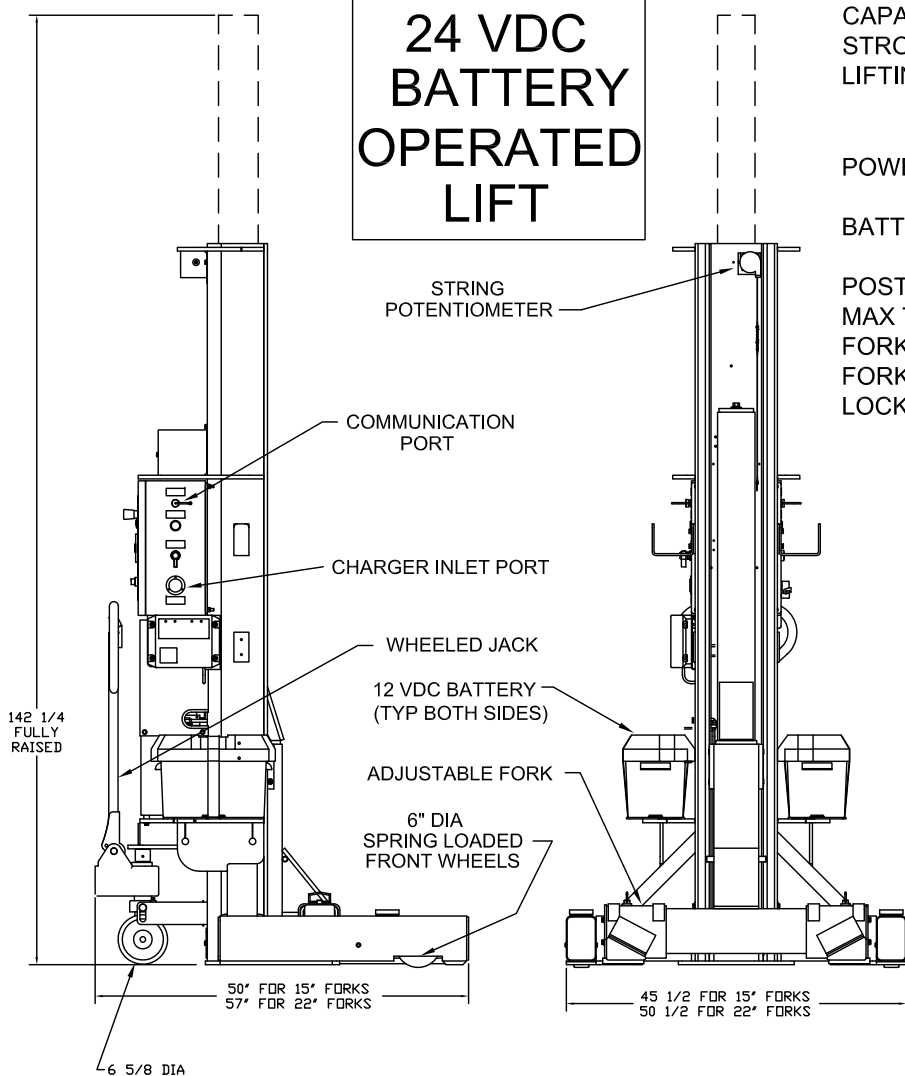

FOLD OR CUT HERE FOR FAXING

### 1. WHAT DOES THE HEAVIEST VEHICLE WEIGH:

LBS

### 2. WHAT DOES THE HEAVIER END OF THE VEHICLE WEIGH? (I.E., FORK LIFT COUNTERWEIGHTS, REAR END MOUNTED ENGINES)

LBS

### 3. OPTIONS INCLUDES: (CHECK ALL THAT APPLY) - (SEE NOTE\*)

#MJS-1830-18, JACK STAND, 18,000 LB, 18" TO 30"
#MJS-3047-18, JACK STAND, 18,000 LB, 30" TO 47"
#MJS-4775-18, JACK STAND, 18,000 LB, 47" TO 75"
#MJS-1830-24, JACK STAND, 24,000 LB, 18" TO 30"
#MJS-3047-24, JACK STAND, 24,000 LB, 30" TO 47"
#MJS-4775-24, JACK STAND, 24,000 LB, 47" TO 75"
#TD-1000-M, TIRE DOLLY, 1000 LB CAPACITY, HAND WINCH
#TD-1000-H, TIRE DOLLY, 1000 LB CAPACITY, FOOT PUMP
#TD-1000-A, TIRE DOLLY, 1000 LB CAPACITY, AIR/HYD
CHASSIS CONTACT LIFTING BEAM (FOR 2 POSTS)
FORK TRUCK ADAPTER KIT (FOR 2 POSTS)
AUTO FRAME CONTACT ADAPTER KIT (FOR 2 POSTS)
WING PLOW ADAPTERS (FOR 2 POSTS)
HMMWV (FRONT TO REAR) ADAPTERS (FOR 2 POSTS)
ADDITIONAL COMMUNICATION CABLE (ONE SET OF 30' LG CABLES INCLUDED PER LIFT)
LONGER COMMUNICATION CABLE ___' LG X ___ QTY
ADDITIONAL DUMMY PLUG SET (ONLY ONE SET INCLUDED PER LIFT)
HAND PENDANT CONTROL WITH 25' CORD (NON-ALCTV)
HAND PENDANT CONTROL (CL 1, DIV 2) WITH 25' CORD (ALCTV CERTIFIED)
WEIGHT GAUGE (SPECIFY QUANTITY OF COLUMNS)
OTHER:

\* NOTE: SOME OPTIONS ARE NOT COMPATIBLE, CONSULT MOHAWK.

### 4. PROPOSED/REQUESTED DELIVERY DATE: \_\_\_/\_\_\_/\_\_\_

5. IS THIS FOR A CONSTRUCTION PROJECT?  YES  NO  
 IF NO, CAN THE LIFT SHIP AT ANYTIME?  YES  NO  
 IF YES, WHEN SHOULD MOHAWK VERIFY PRODUCTION TIME?  
 DATE: \_\_\_/\_\_\_/\_\_\_  
 CONTACT: \_\_\_\_\_  
 TEL: \_\_\_\_\_

6. THIS DRAWING HAS BEEN REVIEWED AND FOUND TO BE ACCEPTABLE TO ALL CUSTOMER'S SPECIFICATIONS INDICATED:

MOHAWK REPRESENTATIVE \_\_\_\_\_ DATE \_\_\_\_\_

OWNER, GENERAL CONTRACTOR AND/OR ARCHITECT. \_\_\_\_\_ DATE \_\_\_\_\_

REV.	DESCRIPTION	DATE	BY	APP'D.
B	QUESTION 9 ADDED	3/11	G.GORE	
CUSTOMER NAME:				
CONTACT:				
PHONE NUMBER:				

7. FINAL ELECTRICAL CONNECTION TO LOCAL/NATIONAL CODE IS THE RESPONSIBILITY OF THE ELECTRICAL CONTRACTOR. MORE THAN ONE POINT OF CONNECTION MAY BE REQUIRED. DISCONNECT SWITCHES, MAIN FUSES, AND MAIN POWER LEADS, ETC, ARE NOT PROVIDED BY MOHAWK RESOURCES LTD.

8. AFTER ALL SPECIFICATIONS HAVE BEEN SELECTED AND APPROVED BY CUSTOMER (SIGNED), MAKE COPY FOR CUSTOMER AND RETURN SIGNED FORM TO MOHAWK AT ADDRESS OR FAX BELOW.

9. ARE THESE COLUMNS BEING ADDED TO AN EXISTING SET OF MOBILE COLUMNS ?

YES  NO

IF YES, PLEASE LIST MODEL NUMBERS AND SERIAL NUMBERS

MODEL #	SERIAL #



MOHAWK RESOURCES LTD.  
 65 VROOMAN AVENUE  
 P.O. BOX 110  
 AMSTERDAM, NY 12010  
 PHN: 1-800-833-2006  
 FAX: 1-518-842-1289  
 www.mohawklifts.com

## MOHAWK MP-18 SERIES 24 VOLT BATTERY OPERATED MOBILE LIFT

FOR SO#: \_\_\_\_\_

SCALE n/a	DRAWN dak	MOHAWK RESOURCES LTD.		
CHECKED	APPROVED	TITLE MP-18 Series 24VDC Data Verification		
DATE 6/07	WEIGHT n/a LB.	FROM n/a	DRAWING NUMBER ZZ958-01-DC	