

MODEL TR-30 SPECIFICATIONS

- Capacity:** TR-30: 30,000 lbs.
- Lifting Speed:** 120 seconds approximately
- Motor Rating:**..... 4 HP, 230VAC, 1Ph (5HP, 3Ø optional)
- Overall Length:**..... 31'-7" width for 25' tracks (multiple lengths available)
- Overall Width:** 14'-4 1/2" to 13'-6 1/2" (wider or narrower available)
- Approach Ramps :** 10 degrees = 4' (longer or shorter available)
- Lifting Stroke:** 6' (72")
- Height @ Full Stroke:**..... 6'-11" (83")
- Track Length:**..... 25' standard (longer or shorter lengths available)
- Track Width:** 28"
- Inside Track Clearance:**..... 3'-6" to 4'-4" standard (wider or narrower available)
- Track Adjustment:**..... 3'-6" inside to 9' outside (wider or narrower available)
- Clearance Between Posts:**..... 11'-9" (wider or narrower available)
- Lifting Mechanism:** Two direct drive hydraulic cylinders front to rear and two leaf chains side to side
- Synchronization (Side to Side):** Leaf chain synchronization side to side
- Synchronization (Fore and Aft):** Hydraulically synchronized master/slave system
- Mechanical Safety Release:** Single point lock release
- Mechanical Safety Locks:** Multi-position every 4" starting at ground level
- Back-up Hydraulic Safety Systems:**.. Pressure compensated flow controls & velocity fuses and manual valving to allow lowering
- Wheel Chocks:** Standard equipment
- Floor Requirements:** 6" thick, 4000 PSI
- Work Area Around/Under Lift:** Clear & unobstructed when lift is raised
- Lift Weight:** 10,680 lbs. (with 25' tracks)
- Warranty:** 3 year Mohawk exclusive lift warranty (see specific warranty details)

Other Available Options:

- Drive through ramps
- Rolling oil drain pan
- Rolling jacks
- Air lines in tracks
- 110V outlets in tracks
- Track lighting



AVAILABLE UNDER DISCOUNTED GOVERNMENT CONTRACT IN ALL 50 STATES



Mohawk Resources, LTD.
 P.O. Box 110
 65 Vrooman Ave
 Amsterdam, NY 12010
 (800) 833-2006
 (518) 842-1431
 FAX: (518) 842-1289
www.mohawklifts.com



GSA contract #GS07F-7099B

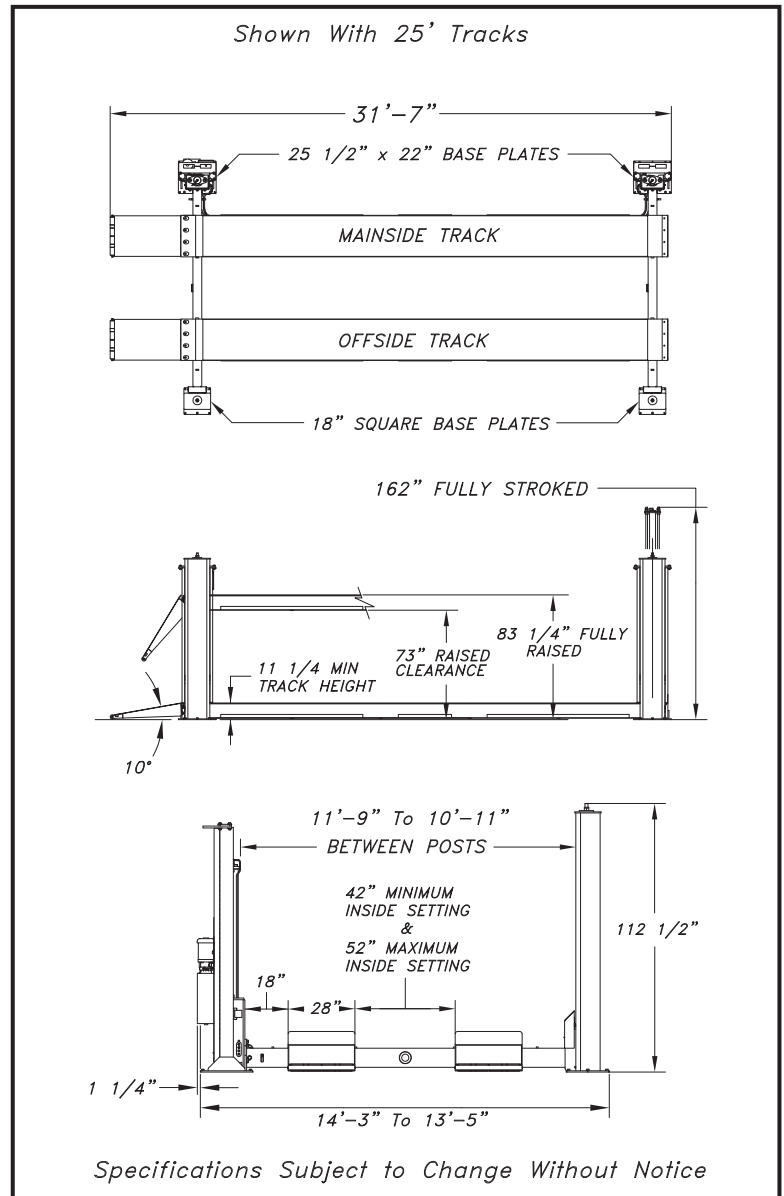

AUTOcad specs available online at
www.mohawklifts.com/architects

Mohawk builds the best products with the finest materials, to the highest standards. Just compare our lifts. Our staff will assist you with a fleet evaluation, design assistance and answer any technical questions you have. We invite your calls.

Mohawk lifts are manufactured in compliance with the following standards: OSHA, ALI, ANSI, ASME, AISI, ASTM, ASA, NEC, AWG, NEMA.
MEETS NATIONAL ANSI & OSHA CODE FOR LIFTS.

DISTRIBUTED BY: