

# MOHAWK TR-SERIES SPECIFICATIONS

## TR LIFT SAMPLE SPECIFICATIONS

<b>Capacities</b> .....	33,000, 35,000, 50,000 or 75,000 lbs.
<b>Lifting speed</b> .....	120 seconds
<b>Motor rating</b> .....	10 HP 220 VAC, 3 Phase
<b>Lifting height (stroke)</b> .....	5'
<b>Runway height at full stroke</b> .....	6'- 2 1/2"
<b>Weight</b> .....	17,000 lbs. (with 25' runways)
<b>Overall length</b> .....	34'-11 3/4" (with 25' runways)
<b>Overall width</b> .....	14'- 5 1/2"
<b>Width between posts</b> .....	11'-10"
<b>Track width</b> .....	24" or 32"
<b>Track Length</b> .....	20', 25', 30' or longer on request
<b>Lifting mechanism</b> .....	(4) Direct drive cylinders using no cables, chains or mechanical lifting screws
<b>Synchronization (side to side)</b> .....	Hydraulic fluid displacement backed by twin opposing leaf chains
<b>Synchronization (fore and aft)</b> .....	Manual or automatic controls gear type flow dividers, integral differential relief valving, with an automatic fluid track leveling system
<b>Mechanical safety systems</b> .....	Multi-position locks in each post starting at 10"
<b>Hydraulic safety systems</b> .....	Integral hydrostatic line blow off flow control devices & velocity fuses
<b>Electrical safety systems</b> .....	Cross-wired electronic systems
<b>Push button electronic console</b> .....	NEMA Type 4 Waterproof enclosure
<b>Controls</b> .....	Solenoid operated
<b>Automatic Wheel chocks</b> .....	Standard equipment front & rear
<b>Concrete requirements</b> .....	4000 PSI concrete 8" thick floor or (4) 6'x6' footings 12" deep
<b>Work area around/under lift</b> .....	Clear and unobstructed with no side obstructions
<b>Warranty</b> .....	3 years- extended cylinder warranty- 1 year on electronic components

U.S. DoD National Stock Number # 4910-21-912-3434

### AVAILABLE OPTIONS

- RJ-50 Electric/Hydraulic Jacking Beam
- Drive through ramps
- TD-1000 and TD-2000 Tire Dollies
- Single Phase Power @ 208-240 VAC
- Transmission Jack
- Longer or Shorter Cross Rails
- Obstacle Sensor Package
- Custom Approach Ramps
- Fluorescent Track Lighting
- JP-50 Jacking Platforms
- Rolling Oil Drain Pan
- Three Phase Power @ 440-480 VAC
- 110V outlets
- Air lines plumbed into tracks
- Scissor Lifting Table
- 4'x4' base plates (for shops with inadequate concrete.)



Mohawk Resources, LTD.  
 P.O. Box 110  
 65 Vrooman Ave  
 Amsterdam, NY 12010  
 (800) 833-2006  
 (518) 842-1431  
 FAX: (518) 842-1289  
**www.mohawklifts.com**



GSA contract #GS07F-7099B

AVAILABLE UNDER  
 GOVERNMENT  
 CONTRACT IN ALL  
 50 STATES

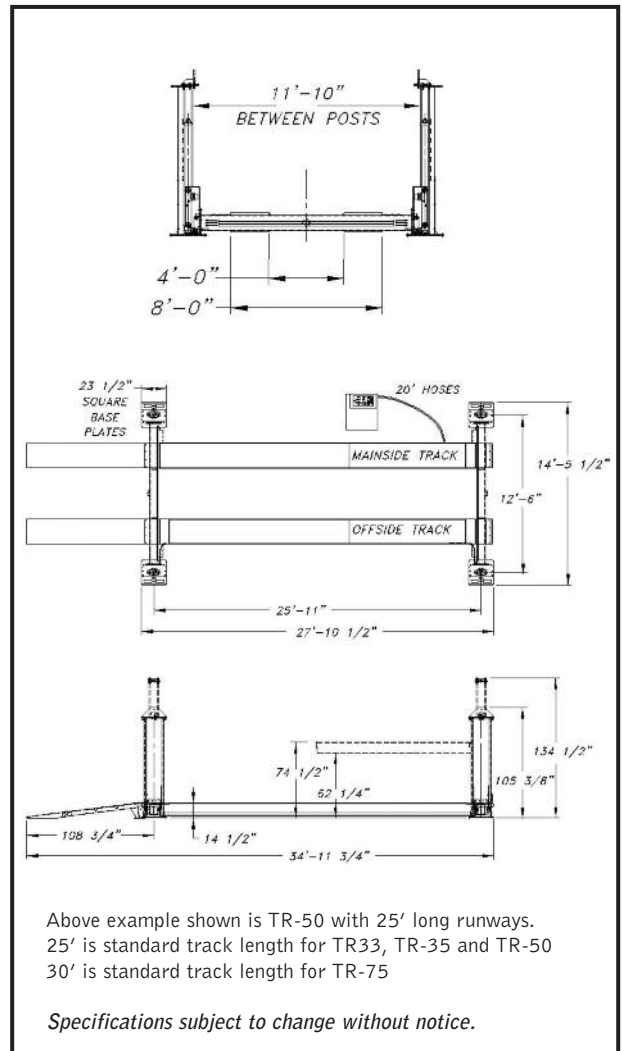

For larger capacity four post lifts, see the models TR-110/TR-120 brochure at [www.mohawklifts.com](http://www.mohawklifts.com)

For longer, shorter, wider, heavier or customized lifts call Mohawk 1-800-833-2006 or 518-842-1431

Mohawk builds the best products with the finest materials, to the highest standards. Just compare our lifts. Our staff will assist you with a fleet evaluation, design assistance and answer any technical questions you have. We invite your calls.

Mohawk lifts are manufactured in compliance with the following standards: OSHA, ALI, ANSI, ASME, AISI, ASTM, ASA, NEC, AWG, NEMA.

MEETS CURRENT NATIONAL ANSI & OSHA SAFETY CODE FOR LIFTS.



DISTRIBUTED BY: