

# MODEL TR-19 or TR-25 SPECIFICATIONS

- Capacity:** ..... 19,000 or 25,000 lbs.
- Lifting Speed:**..... 120 seconds
- Motor Rating:**..... 4 HP/220 V Single-Phase (3 phase optional)
- Lifting Mechanism:** ..... 5" Hydraulic Cylinder Attached to (4) #646 Leaf Chains
- Overall Length:**..... 27'-3"
- Track Length:**..... 20'
- Overall Width:** ..... 12' 6"
- Lifting Stroke:** ..... 5'
- Height @ Full Stroke:** ..... 5' 9 5/16"
- Track Width:**..... 24"
- Track Adjustment:** ..... 4' to 8"
- Clearance Between Posts:** ..... 11' Standard (Wider Available)
- Mechanical Safety Release:** ..... Single Point
- Mechanical Safety Locks:** ..... Multi-Positions
- Back-Up Hydraulic Safety Systems:** ..... Pressure Compensated Flow Controls & Velocity Fuses
- Warranty:** ..... 3 years; (Excluding Motor/Pump)
- Lift Weight:** ..... 5250 lbs

## Available Options

- 25' or 30' tracks and top rail
- 3' track extensions: front, rear, or both
- 3 phase power:
  - 208/230 3 phase 60 hz/460 volt 3 phase 60 hz
  - 380 volt 3 phase 50 hz/575 volt 3 phase 60 hz
- Alignment turntable cut outs in tracks
- Rolling hydraulic jacking beam
- Rolling jacking platform
- Air lines plumbed into tracks
- Obstacle sensor package
- 115 volt duplex outlet
- Runway lighting
- Lockable main switch
- Electric solenoid down valve
- Audible descent alarm
- Drive through ramps
- 25 gallon rolling oil drain pan

Mohawk builds the best products with the finest materials, to the highest standards. Just compare our lifts. Our staff will assist you with a fleet evaluation, design assistance and answer any technical questions you have. We invite your calls.

Mohawk lifts are manufactured in compliance with the following standards: OSHA, ALI, ANSI, ASME, AISI, ASTM, ASA, NEC, AWG, NEMA.

MEETS CURRENT NATIONAL ANSI & OSHA CODE FOR LIFTS. 



[www.facebook.com/mohawklifts](http://www.facebook.com/mohawklifts)

AVAILABLE UNDER DISCOUNTED GOVERNMENT CONTRACT IN ALL 50 STATES



Mohawk Resources, LTD.  
P.O. Box 110  
65 Vrooman Ave  
Amsterdam, NY 12010  
(800) 833-2006  
(518) 842-1431  
FAX: (518) 842-1289  
[www.mohawklifts.com](http://www.mohawklifts.com)

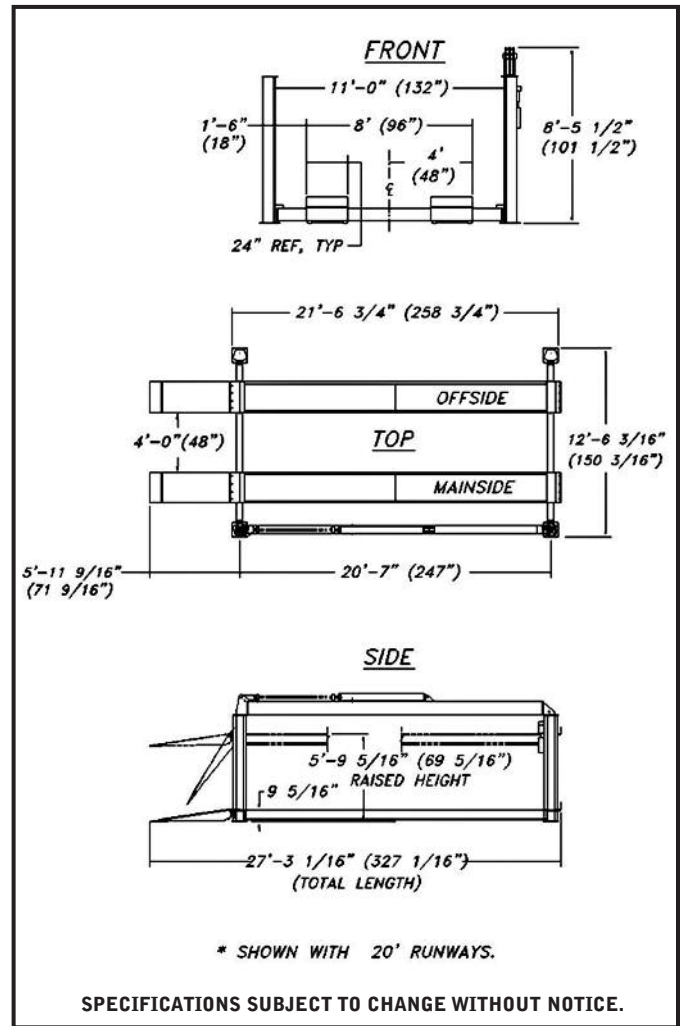

AUTOCAD specs available online at [www.mohawklifts.com/architects](http://www.mohawklifts.com/architects)



National Stock Number 4910-01-424-8934 (NSN)  
AS SEEN IN GSA ADVANTAGE

SIN #253-23 • CAGE CODE-OC714 • DUNS #10-128-9916

DISTRIBUTED BY: