

# MOHAWK

MADE IN THE USA



## MODEL A-7 & A-7A

### 7,000 LB. CAPACITY TWO POST VEHICLE LIFT MANUAL

**THANK YOU  
FOR SENDING IN YOUR  
WARRANTY REGISTRATION  
CARD**

**MOHAWK SERVICE  
DEPARTMENT**

- INSTALLATION
- OPERATION
- MAINTENANCE
- PARTS



Standard Mohawk Models  
A-7 and A-7A

### MOHAWK RESOURCES LTD.

65 VROOMAN AVE.

AMSTERDAM, NY 12010

**TOLL FREE:** 1-800-833-2006

**LOCAL:** 1-518-842-1431

**FAX:** 1-518-842-1289

**INTERNET:** WWW.MOHAWKLIFTS.COM

**E-MAIL:** SERVICE@MOHAWKLIFTS.COM

A7-Master-1-2008.doc

Rev Date 1/22/2008

Part #601-800-260

**READ MANUAL  
THOROUGHLY BEFORE  
INSTALLING,  
OPERATING OR SERVICING  
THIS LIFT !!**

**Deliver these instructions to lift  
owner/user/employer along with  
other instructional materials  
furnished with this lift.**

## **IMPORTANT SAFETY INSTRUCTIONS**

When using your garage equipment, basic safety precautions should always be followed, including the following:

1. Read all instructions.
2. Care must be taken as burns can occur from touching hot parts.
3. Do not operate equipment with a damaged cord or if the equipment has been dropped or damaged - until it has been examined by a qualified serviceman.
3. Do not let cord or hoses come in contact with hot manifolds or moving fan blades.
4. If an extension cord is necessary, a cord with a current rating equal to or more than that of the equipment should be used. Cords rated for less current than the equipment may overheat. Care should be taken to arrange the cord so that it will not be tripped over or pulled.
5. Always unplug equipment from electrical outlet when not in use. Never use the cord to pull the plug from the outlet. Grasp plug and pull to disconnect
6. To reduce the risk of fire, do not operate equipment in the vicinity of open containers of flammable liquids (gasoline). **WARNING: Risk of Explosion:** This equipment has internal arcing and sparking parts which should not be exposed to flammable vapors. This equipment is only suitable for installation in a garage having sufficient air circulation to be considered a non-hazardous location.
7. Adequate ventilation should be provided when working on operating internal combustion engines.
8. Keep hair, loose clothing, fingers, and all parts of body away from moving parts.
9. To reduce the risk of electric shock, do not use on wet surfaces or expose to rain.
10. Use only as described in this manual. Use only manufacturer's recommended attachments.
11. **ALWAYS WEAR SAFETY GLASSES.** Everyday eyeglasses only have impact resistant lenses, they are **NOT** safety glasses.

**SAVE THESE INSTRUCTIONS**

**Rev (8/3/98)**

## APPENDAGE:

Rev (2/9/2006)

### LIFT ENVIRONMENT:

All standard lifts are designed for indoor usage in a normal garage type environment. Any concerns in applications that expose the lift to additional environmental effects, such as paint booths, wash bays, outdoors, high or low temperatures, etc. must be addressed to our engineering department, where provisions may be made to the lift to accommodate the area of use. Our engineering department must be made aware in advance of these conditions and any additional code requirements that must be met.

Also, the foundation for which this lift must be installed on must comply to the minimum specifications as set forth in this manual. Any drainage slopes in the bay where the lift is to be installed must be directed away from the posts to prevent water accumulation at the post bases.

### ACCESSORIES:

All accessories (i.e. Lifting Pads, Height Adapters, Wheel Adapters, Turf Adapters) supplied with this lift are to be used on this lift only. Accessories from other lifts are not acceptable and could result in injury to the user.

If attachments, accessories or configuration modifying components are used on this lift and, if they are not certified for use on this lift, then the certification of this lift shall become null and void. Contact the participant (Mohawk Resources Ltd.) for information pertaining to certified attachments, accessories or configuration modifying components.

### LOCK WARNING:

Latches do not automatically reset after disengagement. After the latches have been manually disengaged, this lift must be raised approximately 2 inches to reactivate the latches.

### LOCKOUT/TAGOUT REQUIREMENTS:

The start switch provided with this unit must not be used as a primary disconnecting means. A separate disconnecting means must be provided in accordance with all applicable codes. It is the responsibility of the owner/user of this unit to provide a proper lockout/tagout device for this unit before or during installation in conformance to ANSI Z244.1 and any local/state/national electrical codes and any OSHA regulations.

### PROPER SELECTION OF POWER SUPPLY CORD:

Acceptable Cord Types: SO, SEO,STO, SOW, SEOO, SOW-A

Cord Size: 12/4

Cord Ampacity: 20 Amps

Cord Wiring: Use Female NEMA Plug supplied with lift and wire as follows (See Diagram Below),

G: Ground (green)

W: Neutral (white)

X: 208 VAC Hot, 110 VAC to ground (Red)

Y: 208 VAC Hot, 110 VAC to ground (Black)

### Face of Plug Represented:

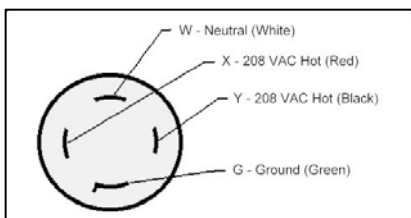

## CEILING HEIGHT WARNING

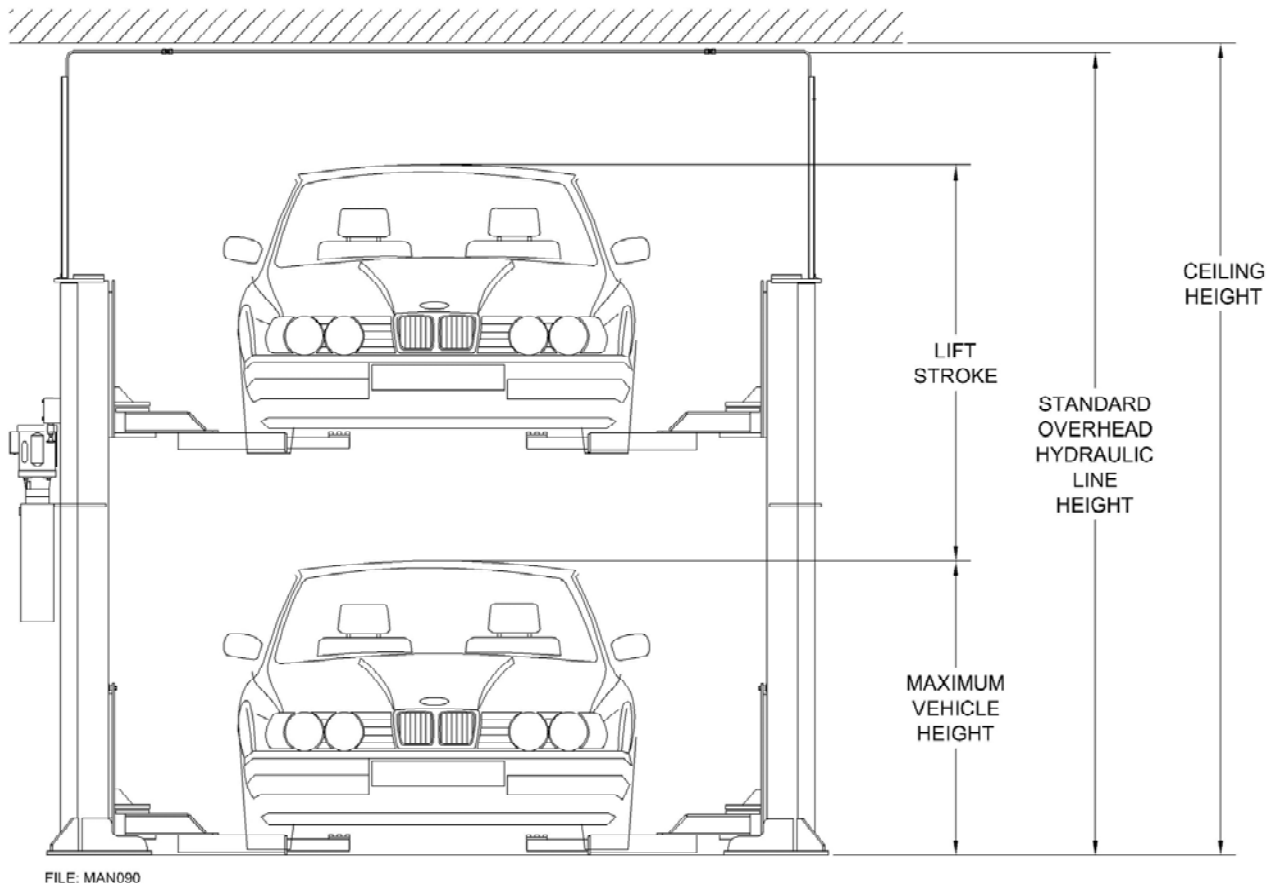

### WARNING:

Ensure that ceiling height\* and/or overhead hydraulic line height is greater than the total lifted height of the tallest vehicle (maximum vehicle height plus lift stroke). Failure to ensure adequate overhead clearance may cause damage to equipment, vehicle and bodily injury to the user.

### NOTICE:

In the event that the ceiling height\* or hydraulic line height is reduced less than the standard heights recommended for the lift, an **OVERHEAD SHUT-OFF DEVICE MUST BE EMPLOYED.**

Note that underground hydraulic lines are available, but the ceiling height\* must still be adequate to provide clearance for the tallest lifted vehicle. Ensure that the whole fleet of vehicles is reviewed and the tallest vehicle used.

\*Overhead obstruction of any kind must be taken into account (i.e. overhead heaters, garage doors, beams, etc..)

HAVE A QUESTION?

**Call your local  
Mohawk distributor  
For parts, service and technical support.**

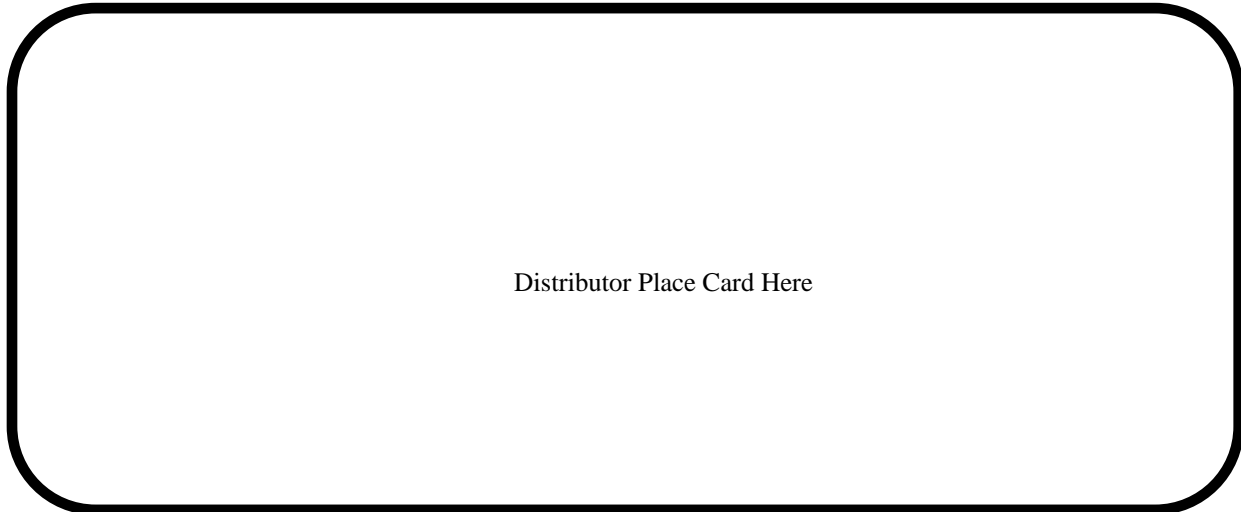

Please have this unit's model and serial number when calling for service.

Model Number \_\_\_\_\_

Serial Number \_\_\_\_\_

**OR CONTACT:**

**MOHAWK RESOURCES LTD.**

65 Vrooman Ave.

P.O. Box 110

Amsterdam, NY 12010

Toll Free: 1-800-833-2006

Local: 1-518-842-1431

Fax: 1-518-842-1289

Internet: [www.MOHAWKLIFTS.com](http://www.MOHAWKLIFTS.com)

E-Mail: [Service@MOHAWKLIFTS.com](mailto:Service@MOHAWKLIFTS.com)



The Automotive Lift Institute (ALI) is a trade association comprised of US and Canadian manufacturers and certain national distributors of automotive lifts. For almost 50 years, the ALI in cooperation with the American National Standards Institute (ANSI) has continued to sponsor the national standard ANSI/ALI ALCTV:2006 "Safety Requirements for Construction, Testing, and Validation for Automotive Lifts."

The new "ALI/ETL Automotive Lift Certification Program" is based on ALI developed methods and criteria for third party testing of automotive lifts to validate conformance with ANSI/ALI ALCTV:2006.

For automotive lifts to be certified, manufacturers must execute an agreement with the ALI and ETL / Intertek Testing Services and must meet certain requirements:

- ◆ Must be structurally tested in accordance with the test requirements as outlined in ANSI/ALI ALCTV:2006.
- ◆ All motor operated units must be listed by a nationally recognized testing laboratory (NRTL) in accordance with ANSI/UL-201.
- ◆ The manufacturer's production facility must meet quality control requirements as set forth in the ANSI Z34.1-1987 and the ALI/ETL Automotive Lift Certification Program Procedural Guide.
- ◆ All manufacturer-provided instructions, manuals, and operator safety documents, must meet the requirements of the ANSI/ALI ALCTV:2006 and ANSI/UL-201.

Lifts meeting these rigid requirements may be listed in the directory of certified lifts and be labeled with the "ALI/ETL certification mark" (Above on right), and, if applicable, the ETL listing mark to ANSI/UL-201.

Mohawk has been a long-standing member of ALI and most of Mohawk's popular models are currently listed and certified. Other Mohawk models are in various stages of testing. To obtain a complete and current certification listing, contact Mohawk Resources Ltd. or visit [www.mohawklifts.com](http://www.mohawklifts.com) or [www.ali-directory.org](http://www.ali-directory.org) To obtain a copy of the current automotive lift standard, contact ALI or ANSI or visit [www.autolift.org](http://www.autolift.org)

Some people purchase quality products and others do not. You are assured of quality when you purchase a Mohawk product in compliance with the certification program.

# MOHAWK WARRANTIES

EFFECTIVE DATE: 5/7/2007 \*

## **GENERAL WARRANTY INFORMATION:**

MOHAWK'S OBLIGATION UNDER THIS WARRANTY IS LIMITED TO REPAIRING OR REPLACING ANY PART OR PARTS RETURNED TO THIS FACTORY, TRANSPORTATION CHARGES PREPAID, WHICH PROVE UPON INSPECTION TO BE DEFECTIVE AND WHICH HAVE NOT BEEN MISUSED. DAMAGE OR FAILURE TO ANY PART DUE TO FREIGHT DAMAGE OR FAULTY MAINTENANCE IS NOT COVERED UNDER THIS WARRANTY. ALL WARRANTY CLAIMS MUST BE PERFORMED IN ACCORDANCE TO MOHAWK'S WARRANTY PARTS RETURN POLICY (CONTACT MOHAWK'S SERVICE DEPARTMENT FOR MORE INFORMATION). THIS WARRANTY DOES NOT COVER MIS-DIAGNOSING OF UNIT OR PARTS RETURNED THAT ARE NON-DEFECTIVE. THIS WARRANTY DOES NOT COVER ANY CONSEQUENTIAL OR INCIDENTAL DAMAGES INCLUDING, BUT NOT LIMITED TO, LOST REVENUES OR BUSINESS HARM. THIS EQUIPMENT HAS BEEN DESIGNED FOR USE IN NORMAL COMMERCIAL VEHICLE MAINTENANCE APPLICATIONS. A SPECIFIC INDIVIDUAL WARRANTY MUST BE ISSUED FOR UNITS THAT DEVIATE FROM INTENDED USAGE, SUCH AS HIGH CYCLE USAGE IN INDUSTRIAL APPLICATIONS, OR USAGE IN EXTREMELY ABUSIVE ENVIRONMENTS, ETC.. MOHAWK RESERVES THE RIGHT TO DECLINE RESPONSIBILITY WHEN REPAIRS HAVE BEEN MADE OR ATTEMPTED BY OTHERS. THIS WARRANTY DOES NOT COVER DOWNTIME EXPENSES INCURRED WHEN UNIT IS IN REPAIR. THE MODEL NAME AND SERIAL NUMBER OF THE EQUIPMENT MUST BE FURNISHED WITH ALL WARRANTY CLAIMS. THIS WARRANTY STATEMENT CONTAINS THE ENTIRE AGREEMENT BETWEEN MOHAWK RESOURCES LTD. AND THE PURCHASER UNLESS OTHERWISE SPECIFICALLY EXPRESSED IN WRITING. THIS NON-TRANSFERABLE WARRANTY APPLIES TO THE ORIGINAL PURCHASER ONLY. THIS WARRANTY IS APPLICABLE TO UNITS LOCATED ONLY IN THE UNITED STATES OF AMERICA AND CANADA. CONTACT MOHAWK RESOURCES LTD. FOR SPECIFIC WARRANTY PROVISIONS FOR UNITS LOCATED OUTSIDE OF THESE COUNTRIES.

## **STRUCTURAL COMPONENTS (ALL LIFTS):**

ALL STRUCTURAL AND MECHANICAL COMPONENTS OF THIS UNIT ARE GUARANTEED FOR THE BELOW STATED TIME FRAME, SPECIFIC TO MODEL LISTED, FROM THE DATE OF INVOICE, AGAINST DEFECTS IN WORKMANSHIP AND/OR MATERIALS WHEN LIFT IS INSTALLED AND USED ACCORDING TO SPECIFICATIONS.

**5-YEAR:** MODELS A-7, SYSTEM IA, SYSTEM IA-10, TOMAHAWK-9000, LMF-12, TP-15, TP-16, TP-18, TP-20, TP-26, TP-30, & TL-7.

**3-YEAR:** MODELS TR-19, TR-25, FL-25, TR-33, TR-35, TR-50, TR-75, TR-110, TR-120, MP-SERIES, RP-SERIES LIFTS.

**2-YEAR:** MODELS PARALLELOGRAM SERIES LIFTS.

**1-YEAR:** MODELS HR-6, TD-1000, CT-1000, USL-6000.

## **POWER UNIT (ALL LIFTS):**

ALL POWER UNIT COMPONENTS (MOTOR, PUMP AND RESERVOIR) ARE GUARANTEED FOR TWO YEARS FOR PARTS (ONE YEAR LABOR), FROM THE DATE OF INVOICE, AGAINST DEFECTS IN WORKMANSHIP AND/OR MATERIALS WHEN THE LIFT IS INSTALLED AND USED ACCORDING TO SPECIFICATIONS.

## **HYDRAULIC CYLINDERS (MODEL SPECIFIC LIFTS):**

SEE MOHAWK'S "EXTENDED LIFETIME CYLINDER WARRANTY" FOR SPECIFIC WARRANTY PROVISIONS FOR HYDRAULIC CYLINDERS. THE "EXTENDED LIFETIME CYLINDER WARRANTY" IS APPLICABLE TO THE FOLLOWING MOHAWK LIFTS ONLY: A-7, SYSTEM IA, SYSTEM IA-10, LMF-12, TP-15, TP-18, TP-20, TP-26, TP-30. ALL OTHER MODELS ARE GUARANTEED FOR TWO YEARS PARTS AND ONE YEAR LABOR (EXCEPT HR-6, WHICH IS ONE YEAR PARTS ONLY), FROM THE DATE OF INVOICE, AGAINST DEFECTS IN WORKMANSHIP AND/OR MATERIALS WHEN THE LIFT IS INSTALLED AND USED ACCORDING TO SPECIFICATIONS.

## **ELECTRICAL COMPONENTS (ALL LIFTS):**

ALL ELECTRICAL COMPONENTS (EXCLUDING MOTOR) ARE GUARANTEED FOR ONE YEAR FOR PARTS AND LABOR, FROM THE DATE OF INVOICE, AGAINST DEFECTS IN WORKMANSHIP AND/OR MATERIALS WHEN THE LIFT IS INSTALLED AND USED ACCORDING TO SPECIFICATIONS.

## **PNEUMATIC-AIR COMPONENTS (ALL LIFTS):**

ALL PNEUMATIC (AIR) COMPONENTS (I.E. AIR CYLINDERS AND POPPET AIR VALVES) ARE GUARANTEED FOR ONE YEAR FOR PARTS AND LABOR, FROM THE DATE OF INVOICE, AGAINST DEFECTS IN WORKMANSHIP AND/OR MATERIALS WHEN THE LIFT IS INSTALLED AND USED ACCORDING TO SPECIFICATIONS.

## **STANDARD OPTIONS (ALL LIFTS):**

ALL STANDARD OPTIONS OF THIS UNIT ARE GUARANTEED FOR ONE YEAR FOR PARTS AND LABOR, FROM THE DATE OF INVOICE, AGAINST DEFECTS IN WORKMANSHIP AND/OR MATERIALS WHEN LIFT IS INSTALLED AND USED ACCORDING TO SPECIFICATIONS.

## **SPECIAL AND/OR CUSTOMIZED LIFTS AND OPTIONS:**

ALL "SPECIAL" LIFTS AND/OR "CUSTOMIZED" OPTIONS ON THIS UNIT ARE GUARANTEED FOR ONE YEAR FOR PARTS ONLY (EXCLUDING LABOR), FROM THE DATE OF INVOICE, AGAINST DEFECTS IN WORKMANSHIP AND/OR MATERIALS WHEN THE LIFT IS INSTALLED AND USED ACCORDING TO SPECIFICATIONS.

**WARRANTY EXCEPTIONS (ALL LIFTS):**

**ADJUSTMENTS:** THIS WARRANTY DOES NOT COVER CASUAL AND ROUTINE ADJUSTMENTS SUCH AS, BUT NOT LIMITED TO: FITTINGS, J-BAR ADJUSTMENTS, ANCHOR BOLT RE-TIGHTENING, OR ANY SHIMMING OR ADJUSTMENTS REQUIRED DURING A PROPER AND PROFESSIONAL INSTALLATION BY A QUALIFIED INSTALLER.

**MAINTENANCE AND INSPECTIONS:** IF THIS UNIT IS NOT MAINTAINED AND INSPECTED IN ACCORDANCE TO THE RELEVANT SECTIONS IN THE USERS MANUAL FOR THIS SPECIFIC MODEL, WARRANTY IS SUSPENDED UNTIL THE LIFT CONDITION IS PROVEN TO BE TO MOHAWK'S SATISFACTION (ANY CURRENT CLAIMS WILL NOT BE PAID UNTIL THIS REQUIREMENT IS MET). OSHA, ANSI AND MOHAWK REQUIRE THAT RECORDS MUST BE MAINTAINED TO PROVE THAT INSPECTIONS AND MAINTENANCE OF THIS UNIT HAVE BEEN ROUTINELY PERFORMED BY QUALIFIED INDIVIDUALS.

**ABUSE:** IF THIS UNIT IS FOUND TO BE OVERLOADED (PURPOSELY OR UNKNOWINGLY), USED IN A SITUATION BEYOND ITS INTENDED FUNCTION, NOT MAINTAINED OR INSPECTED REGULARLY, OR USED IN AN ABUSIVE ENVIRONMENT, ETC., THIS WARRANTY IS VOID IN ITS ENTIRETY.

**NON-EXISTENT PROBLEMS:** FOR SERVICE VISITS, PART REPLACEMENTS, LABOR, ETC. FOR PARTS FOUND TO BE NON-DEFECTIVE, OR FOR A UNIT DIS-FUNCTION THAT DOES NOT EXIST, IT IS THE LIFT OWNER THAT REQUESTED THE SERVICE VISIT WHO BEARS THE RESPONSIBILITY OF ALL RELATED EXPENSES.

**BATTERIES:** ALL BATTERIES CARRY THE BATTERY MANUFACTURER'S WARRANTY. MAINTENANCE REQUIREMENTS AND ABUSE PROVISIONS ARE AS STATED BY THE BATTERY MANUFACTURER. REFER TO BATTERY MANUFACTURER'S WARRANTY.

**\* THIS WARRANTY SUPERSEDES ALL OTHER WARRANTY POLICIES PREVIOUSLY STATED AND IN ALL OTHER MOHAWK PRODUCT SPECIFIC LITERATURE (MANUALS, BROCHURES, ETC.).**

## **EXTENDED LIFETIME CYLINDER WARRANTY**

AS THE ORIGINAL PURCHASER OF A MOHAWK LIFT MANUFACTURED BY MOHAWK RESOURCES, LTD. YOU ARE ENTITLED TO AN EXTENDED CYLINDER SEAL KIT REPAIR WARRANTY. TO QUALIFY FOR THIS WARRANTY, THE FOLLOWING CONDITIONS MUST BE MET:

- ◆ ALL LIFTS MUST BE REGISTERED WITH MOHAWK RESOURCES, LTD., P.O. BOX 110, 65 VROOMAN AVENUE, AMSTERDAM, NY 12010, WITH THE ORIGINAL CUSTOMER NAME, ADDRESS AND PHONE NUMBER, WITHIN 30 DAYS OF INSTALLATION.  
(PLEASE USE THE POSTAGE PAID WARRANTY REGISTRATION CARD ATTACHED TO THE FRONT OF THIS MANUAL.)
- ◆ ANY CYLINDER THAT IS PAST ITS NORMAL 5-YEAR WARRANTY PERIOD MUST BE SHIPPED FREIGHT PRE-PAID TO THE MOHAWK PLANT.
- ◆ UPON COMPLETION OF INSTALLING A COMPLETE SEAL KIT, MOHAWK WILL SHIP THE CYLINDER TO YOU, FREIGHT COLLECT.
- ◆ MOHAWK'S OBLIGATION UNDER THIS WARRANTY IS LIMITED TO REPAIRING ANY CYLINDER, WHICH UPON INSPECTION HAS NOT BEEN MISUSED. MOHAWK RESERVES THE RIGHT TO DECLINE RESPONSIBILITY WHEN THE REPAIRS HAVE BEEN MADE, OR ATTEMPTED BY OTHERS. THE FOREGOING CONTAINS THE ENTIRE AGREEMENT BETWEEN MOHAWK RESOURCES, LTD. AND THE PURCHASER, UNLESS SPECIFICALLY EXPRESSED IN WRITING. THIS WARRANTY IS NON-TRANSFERABLE AND RUNS TO THE ORIGINAL PURCHASER ONLY.

THIS IS NOT A "LEND A CYLINDER" POLICY. AS STATED ABOVE, YOUR ORIGINAL CYLINDER (WHEN OUT OF ITS ORIGINAL 5-YEAR WARRANTY) WILL HAVE ITS SEALS REPLACED, WITH ALL FREIGHT CHARGES THE RESPONSIBILITY OF YOU, THE CUSTOMER.

**CONTENTS****TEXT**

	<b>PAGE</b>
APPENDAGES.....	2
SPECIFICATIONS.....	3
PACKING LIST.....	4
RECOMMENDED TOOL LIST.....	5
BEFORE INSTALLING A LIFT / WEJ-IT INSTALLATION.....	6
INSTALLATION INSTRUCTIONS.....	7-8
SAFETY TIPS.....	9
LIFT FINAL CHECKOUT.....	10
2-POST LIMITATIONS AND ADAPTER USAGE.....	11
PRE - OPERATION CHECK LIST / LIFTING PROCEDURES.....	12
MAINTENANCE PROCEDURES.....	13
CHAIN INSPECTION AND MAINTENANCE.....	14
CABLE INSPECTION AND MAINTENANCE.....	15
TROUBLE SHOOTING.....	16-17
SERVICE CHART.....	18
MAINTENANCE CHART.....	18

**FIGURES / DIAGRAMS**

	<b>FIGURE</b>	<b>PAGE</b>
FLOOR MODIFICATION.....	1	20
BAY SIGHT LAYOUT / INSTALLATION DIMENSIONS.....	2	21
CARRIAGE STOP ASSEMBLY.....	3	22
WEJ-IT INSTALLATION.....	4, 5, 6	23-25
POST-LEVELING.....	7	26
POST-SHIMMING.....	8	27
CYLINDER SHIMS.....	9	28
CENTERING VEHICLE / BASE PLATE DETAIL.....	10	29
UNEVEN FLOORS.....	11	30
SPECIAL LIFTING PADS.....	12	31
POWER UNIT.....	13	32
CHAIN BREAK SAFETY CABLE.....	14	33

**PARTS**

	<b>FIGURE</b>	<b>PAGE</b>
ISOMETRIC FINAL ASSEMBLY.....	MAN146	35
MAIN SIDE ASSEMBLY.....	MAN145	36
OFF SIDE ASSEMBLY.....	MAN144	37
HYDRAULIC SYSTEM.....	MAN101	38
CARRIAGE, CHAIN, & ARM LOCK.....	MAN143	39
LATCH BODY ASSEMBLY.....	MAN142	40
YOKE ASSEMBLY.....	MAN104	41
HEIGHT ADAPTER & BRACKET / CYLINDER CLAMPS.....	MAN148	42
CARRIAGE / SWING ARMS / SLIDERS / LIFTING PADS.....	MAN147	43
LEG WELDMENT / LINE SUPPORTS / CARRIAGE STOPS.....	MAN127	44
TAG & DECAL LOCATIONS.....	MAN128	45
MAIN SIDE CYLINDER ASSEMBLY.....	MAN109	46
OFF SIDE CYLINDER ASSEMBLY.....	MAN110	47
SMALL PARTS BAG.....	MAN131	48
PARTS BOX.....	MAN132	49
DIVERTER VALVE ASSEMBLY.....	MAN235	50
CHAIN COVER ASSEMBLY.....	MAN141	51

**NEW SLAB RECOMMENDATIONS**

	<b>PAGE</b>
SLAB REQUIREMENTS & NEW SLAB RECOMMENDATIONS.....	52-60

ALL INFORMATION, ILLUSTRATIONS, AND SPECIFICATIONS IN THIS MANUAL ARE BASED ON THE LATEST PRODUCT INFORMATION AVAILABLE AT THE TIME OF PRINTING. WE RESERVE THE RIGHT TO MAKE CHANGES AT ANY TIME WITHOUT NOTICE.

## APPENDAGES

RECOMMENDATIONS BY THE INDIVIDUAL USER OR USING ORGANIZATION FOR IMPROVING THIS PUBLICATION OR ANY ASPECT OF THE PRODUCT ARE ENCOURAGED AND SHOULD BE FORWARDED IN WRITING TO:

**MOHAWK RESOURCES LTD.  
PRODUCT IMPROVEMENTS  
65 VROOMAN AVE.  
AMSTERDAM, NY, 12010**

THIS IS NOT A VEHICLE LIFTING PROCEDURE MANUAL AND NO ATTEMPT IS MADE OR IMPLIED HEREIN TO INSTRUCT THE USER IN LIFTING METHODS PARTICULARLY TO THE INDIVIDUAL APPLICATION OF THE EQUIPMENT DESCRIBED IN THIS MANUAL. RATHER, THE CONTENTS OF THIS MANUAL ARE INTENDED AS A BASE LINE FOR OPERATION, MAINTENANCE, TROUBLE SHOOTING, AND PARTS LISTING OF THE UNIT AS IT STANDS ALONE AND AS IT IS INTENDED AND ANTICIPATED TO BE USED IN CONJUNCTION WITH OTHER EQUIPMENT.

PROPER APPLICATION OF THE EQUIPMENT DESCRIBED HEREIN IS LIMITED TO THE PARAMETERS DETAILED IN THE SPECIFICATIONS AND THE USES SET FORTH IN THE DESCRIPTIVE PASSAGES. ANY OTHER PROPOSED APPLICATION OF THIS EQUIPMENT SHOULD BE DOCUMENTED AND SUBMITTED IN WRITING TO MOHAWK RESOURCES LTD. FOR EXAMINATION. THE USER ASSUMES FULL RESPONSIBILITY FOR ANY EQUIPMENT DAMAGE, PERSONAL INJURY, OR ALTERATION OF THE EQUIPMENT DESCRIBED IN THIS MANUAL OR ANY SUBSEQUENT DAMAGES.

DO NOT WELD, APPLY HEAT, OR MODIFY THIS EQUIPMENT IN ANY MANNER WITHOUT WRITTEN AUTHORIZATION FROM MOHAWK RESOURCES LTD. CERTAIN ALLOY OR HEAT-TREATED COMPONENTS MAY BE DISTORTED OR WEAKENED, RESULTING IN AN UNSAFE CONDITION.

MOHAWK RESOURCES LTD. IS NOT RESPONSIBLE FOR DISTORTIONS, WHICH RESULT FROM WELDING ON THIS EQUIPMENT AFTER MANUFACTURING IS COMPLETED. UNAUTHORIZED WELDING, APPLICATION OF HEAT, OR MODIFICATION OF THIS EQUIPMENT VOIDS ANY AND / OR ALL APPLICABLE WARRANTIES COVERING THIS EQUIPMENT.

ALL WARRANTIES APPLICABLE TO THIS EQUIPMENT ARE CONTINGENT ON STRICT ADHERENCE TO THE MAINTENANCE SCHEDULES AND PROCEDURES IN THIS MANUAL.

KEEP ALL SHIELDS AND GUARDS IN PLACE. INSURE ALL SAFETY MECHANISMS ARE OPERABLE. KEEP HANDS, FEET, AND CLOTHING AWAY FROM POWER-DRIVEN AND MOVING PARTS.

### WARNING

- DO NOT INSTALL THIS UNIT IN A PIT OR DEPRESSION DUE TO FIRE OR EXPLOSION RISK

### IMPORTANT NOTE

A LEVEL FLOOR IS SUGGESTED FOR A PROPER INSTALLATION SITE AND WILL ENSURE LEVEL LIFTING. SMALL DIFFERENCES IN FLOOR SLOPES MAY BE COMPENSATED FOR WITH SPECIAL LIFTING PADS. ANY MAJOR SLOPE CHANGES WILL AFFECT THE LOW PROFILE HEIGHT OF THE LIFTING PADS AND / OR THE UNITS LEVEL LIFTING PERFORMANCE. IF A FLOOR IS OF QUESTIONABLE SLOPE, CONSIDER A SURVEY OF THE SIGHT AND / OR THE POSSIBILITY OF POURING A NEW LEVEL CONCRETE SLAB SECTION. SIMPLY STATED, FOR OPTIMUM LEVEL LIFTING, THE EQUIPMENT, AT BEST, CAN LIFT ONLY AS

LEVEL AS THE FLOOR ON WHICH IT IS LOCATED... AND SHOULD NOT BE EXPECTED TO COMPENSATE FOR DRASTIC FLOOR SLOPE DIFFERENCES.

THIS EQUIPMENT MUST BE INSTALLED ON A LEVEL CONCRETE FLOOR WITH A MINIMUM THICKNESS OF 4-1/2" THE CONCRETE MUST BE AGED AT LEAST (28) TWENTY EIGHT DAYS PRIOR TO INSTALLATION AND HAVE A MINIMUM COMPRESSIVE STRENGTH OF 4000 P.S.I.

DO NOT INSTALL THIS UNIT ON ANY ASPHALT SURFACE.

DO NOT INSTALL THIS UNIT ON ANY SURFACE OTHER THAN CONCRETE CONFORMING TO THE MINIMUM SPECIFICATIONS STATED IN THE **PRE-EXISTING FLOOR REQUIREMENTS SECTION**.

DO NOT INSTALL THIS UNIT ON EXPANSION SEAMS OR ON CRACKED, DEFECTIVE CONCRETE. CHECK WITH BUILDING ARCHITECT.

DO NOT INSTALL THIS UNIT ON A SECOND FLOOR OR ANY GROUND FLOOR WITH A BASEMENT BENEATH WITHOUT WRITTEN AUTHORIZATION FROM THE BUILDING ARCHITECT.

### INSTALL THIS EQUIPMENT ON CONCRETE ONLY

IF, FOR ANY REASON, A NEW CONCRETE SLAB SECTION IS REQUIRED, THE MINIMUM THICKNESS, COMPRESSIVE STRENGTH, AND AGING ARE MANDATORY. FOR YOUR PROTECTION, CERTIFIED STRENGTH DOCUMENTATION SHOULD BE OBTAINED FROM THE FIRM WHO SUPPLIES THE CONCRETE MIXTURE AT THE TIME OF THE POUR. SPECIAL CONSIDERATION SHOULD BE MADE TO THE JOINING OF THE EXISTING FLOOR AND THE NEW SECTION BEING ADDED. CHECK WITH BUILDING ARCHITECT. THE SUGGESTED SIZE OF THE NEW CONCRETE SLAB SECTION IS SHOWN IN THE **NEW SLAB RECOMMENDATIONS SECTION**.

### CAUTION

THE EQUIPMENT DESCRIBED IN THIS MANUAL COULD BE POTENTIALLY DANGEROUS IF IMPROPERLY OR CARELESSLY OPERATED. FOR THE PROTECTION OF ALL PERSONS AND EQUIPMENT, ONLY COMPETENTLY TRAINED OPERATORS WHO ARE CRITICALLY AWARE OF THE PROPER OPERATING PROCEDURES, POTENTIAL DANGERS, AND SPECIFIC APPLICATION OF THIS EQUIPMENT SHOULD BE ALLOWED TO TOUCH THE CONTROLS AT ANY TIME.

SAFE OPERATION OF THIS EQUIPMENT IS DEPENDENT ON USE, IN COMPLIANCE WITH THE OPERATION PROCEDURES OUTLINED IN THIS MANUAL ALONG WITH THE MAINTENANCE AND INSPECTION PROCEDURES WITH CONSIDERATION OF PREVAILING CONDITIONS.

THE EQUIPMENT DESCRIBED IN THIS MANUAL IS NEITHER DESIGNED NOR INTENDED FOR ANY APPLICATION ALONE OR IN CONJUNCTION WITH ANY OTHER EQUIPMENT THAT INVOLVES THE LIFTING OR MOVING OF **PERSONS**.

ALWAYS CONSULT THE VEHICLE LIFTING GUIDE FOR THE PROPER LIFTING POINTS ON ANY VEHICLE. THESE GUIDES ARE AVAILABLE FROM THE VEHICLE MANUFACTURERS. AFTER LIFTING THE VEHICLE TO THE DESIRED HEIGHT, ALWAYS LOWER THE UNIT ONTO THE MECHANICAL SAFETIES. THE FORMING OF GOOD OPERATIONAL WORK HABITS WILL ELIMINATE OVERSIGHTS IN THE USE OF PROVIDED SAFETY DEVICES.

**A-7 SPECIFICATIONS**

**A-7 SPECIFICATIONS**

LIFT TYPE / TWO POST	ELECTRIC / HYDRAULIC
GROSS LIFTING CAPACITY	7,000 LBS.
PER ARM CAPACITY	1,750 LBS.
LIFTING SPEED APPROX.	45 SECONDS
LIFTING HEIGHT	72 INCHES
OVERALL WIDTH	127 INCHES
WIDTH BETWEEN POST	91 INCHES
WIDTH BETWEEN LIFTING ARMS	83.3 INCHES
POST HEIGHT	96 INCHES
OVERHEAD HYDRAULIC LINES	144 INCHES
LIFTING PAD HEIGHT (MIN)	4 INCHES
LIFTING PAD HEIGHT (MAX)	85 INCHES
SHIPPING WEIGHT	1,900 LBS.

**POWER UNIT SPECIFICATIONS**

BRAND NAME	MONARCH
MODEL	M-4509-0110
POWER UNIT TYPE	VERTICAL
MOTOR VOLTAGE	208 / 230
F.L.A. AT RATED CAPACITY	13.9 / 13
MOTOR HORSEPOWER	2 1/2
MOTOR PHASE	SINGLE
MOTOR CYCLE / HERTZ	60
MOTOR SPEED (R.P.M.)	3450
PUMP FLOW (G.P.M.)	2.39 @ 3450 R.P.M.
RELIEF VALVE SETTING	2050 P.S.I.
WORKING PRESSURE	1800 P.S.I.
RESERVOIR CAPACITY	2.5 GALLONS
HYDRAULIC FLUID MEDIUM	DEXRON III

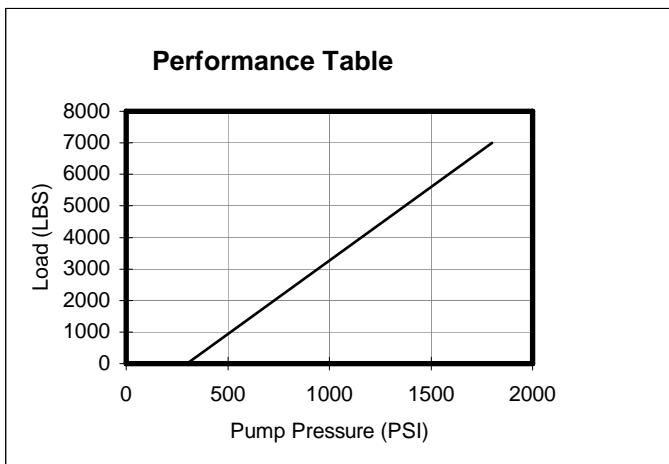

**SUGGESTED SITE SELECTION / BAY SIZE**

WIDTH	DEPTH	HEIGHT
15 FEET	20 FEET	12 FEET

**NOTE**

THE PLACEMENT OF THE UNIT IS DETERMINED BY THE TYPE (LENGTH, WIDTH, HEIGHT) OF VEHICLE BEING SERVICED.

**WEJ-IT ANCHOR SPECIFICATIONS**

LENGTH	DRILL DEPTH	DRILL SIZE	DRILL SIZE MIN.	DRILL SIZE MAX.	TORQUE
5 INCH	THRU	3/4 IN.	.775 IN.	.787 IN.	SEE ANCHOR SPECS

**PRE-EXISTING FLOOR REQUIREMENTS**

MINIMUM THICKNESS	MINIMUM COMPRESSIVE STRENGTH	MINIMUM AGING
4 - 1/2 IN	4000 P.S.I.	28 DAYS

DO NOT INSTALL ANY MOHAWK LIFT ON ANY SURFACE OTHER THAN CONCRETE CONFORMING TO THE MINIMUM COMPRESSIVE STRENGTH, MINIMUM AGING, AND THE MINIMUM THICKNESS STATED ABOVE.

DO NOT INSTALL ANY MOHAWK LIFT ON EXPANSION SEAMS OR ON CRACKED, OR DEFECTIVE CONCRETE.

DO NOT INSTALL ANY MOHAWK LIFT ON SECONDARY FLOOR LEVELS OR ANY SURFACE WITH A BASEMENT BENEATH WITHOUT WRITTEN AUTHORIZATION FROM THE BUILDING ARCHITECT. NEVER HAND MIX YOUR OWN CONCRETE.

IF FOR ANY REASON A NEW CONCRETE SLAB SECTION IS REQUIRED, FOLLOW THE INSTRUCTIONS FOR THE FLOOR MODIFICATION DATA.

**FLOOR MODIFICATION DATA  
NEW FLOOR SECTION**

THICKNESS	SLAB SIZE WIDTH X LENGTH	CUBIC YARDS
12 INCHES	48 INCHES X 144 INCHES	2.1

IF, FOR ANY REASON, A NEW CONCRETE SLAB SECTION IS REQUIRED, MINIMUM THICKNESS, COMPRESSIVE STRENGTH, AND PROPER AGING IS MANDATORY.

THE NEW SLAB SECTION MUST BE TOTALLY SURROUNDED BY AN EXISTING CONCRETE FLOOR THAT IS STRUCTURALLY SOUND. CERTIFIED STRENGTH DOCUMENTATION SHOULD BE OBTAINED FROM THE FIRM WHO SUPPLIES THE CONCRETE MIXTURE AT THE TIME OF THE POUR.

**NEVER HAND MIX THE CONCRETE.. REFER TO NEW SLAB RECOMMENDATIONS SECTION.**

**A-7 PACKING LIST****\*\*\* ALSO SEE DRAWINGS MAN131 / MAN132 IN PARTS MANUAL \*\*\***

ORDER NUMBER	PART NUMBER	PART DESCRIPTION	QTY.
	<b>007-010-012</b>	<b>PARTS BOX CONTENTS</b>	
563	009-001-141	CARRIAGE STOP	4
064	025-002-126	HEIGHT ADAPTER BRACKET	2
045	025-002-128	HEIGHT ADAPTER (6 INCH)	4
044	025-002-127	HEIGHT ADAPTER (3 INCH)	4
460	601-170-008	HUBBLE CONNECTOR (FEMALE)	1
068	007-007-036	LIFTING PAD	4
095	007-010-016	MANUAL (INSTALLATION)	1
623	007-007-075	SHIM BAG	1
	007-010-014	SMALL PARTS BAG	1
112	601-630-001	SPRAY PAINT (RED)	1
113	601-630-002	SPRAY PAINT (YELLOW)	1
146	007-007-132	SWING ARM PIN	4
	600-670-002	WEJ-IT ANCHOR (3/4 x 5)	14
	600-690-015	NUT, LOCK (JAM) 1 1/2-12 NF	4
	007-010-103	SWING ARM PIN, 1 1/2 DIA x 6 3/4	4
	<b>007-010-014</b>	<b>SMALL PARTS BAG CONTENTS</b>	
171	600-640-019	BOLT, 1/4-20 X 1-1/2	8
258	600-690-005	NUT, LOCK, 1/4-20 NC	8
259	600-710-004	WASHER, 1/4 SAE FLAT	4
621	600-710-014	WASHER, 1-3/8 SAE FLAT	8
	600-710-006	WASHER, FLAT, FENDER, 5/16 ID X 1 1/2 OD	4
021	601-310-005	BREATHER CAP	1
094	601-420-011	FITTING, DOUBLE MALE UNION # 6 JIC	4
409	601-710-001	DOUBLE LINE CLIP	4
	<b>007-007-075</b>	<b>SHIM BAG CONTENTS</b>	
633	600-740-001	SHIM, 1/16 (BLUE)	8
634	600-740-002	SHIM, 1/8 (RED)	8
635	600-740-003	SHIM, 1/4 (BLACK)	8

**RECOMMENDED TOOL LIST**

<b>SIZE / QTY</b>	<b>DESCRIPTION</b>	<b>USED IN</b>
1 - 1/8 IN	WRENCH & SOCKET	WEJ-IT ANCHORS
15 / 16 IN	WRENCH & SOCKET	CARRIAGE STOPS
11/16 IN	WRENCH	HYDRAULIC LINES
5/8 IN	WRENCH	HYDRAULIC LINES
1/2 IN	WRENCH & SOCKET	BACK BOARD / CYLINDER RETAINER
7/16 IN	WRENCH	SWING ARM RESTRAINT ASSEMBLIES
1	RATCHET WRENCH	AS NEEDED
1	SNAP RING PLIERS	SWING ARM PINS
1	VICE GRIPS	AS NEEDED
1	CRESCENT WRENCH	AS NEEDED
1	4 FT BUBBLE LEVEL	VERIFY LEVEL ASSEMBLY
1	PRY BAR	MOVING HEAVY ITEMS
1	TIN SNIPS	PACKAGING BANDING
1	CHALK LINE	FLOOR LAYOUT
1	SOAP STONE	FLOOR LAYOUT
1	25 FT TAPE MEASURE	FLOOR LAYOUT / SQUARING POST
1	MEDIUM HAMMER	WEJ-IT ANCHORS
1	HAMMER DRILL	DRILLING CONCRETE
1	DRILL BIT (3/4 INCH)	DRILLING CONCRETE
1 TON	LIFTING DEVICE	LIFTING / MOVING HEAVY ITEMS
8 FT	STEP LADDER	ASSEMBLE ELEVATED ITEMS
100 FT	LEAD CORD	OPERATE ELECTRICAL TOOLS

## BEFORE INSTALLING A LIFT

### IMPORTANT

BEFORE INSTALLING A MOHAWK LIFT THERE ARE A FEW ITEMS THAT MUST BE INSPECTED. EACH REPAIR SHOP BAY IS DIFFERENT. IN AN ATTEMPT TO PREVENT OVERSIGHTS, ALL OF THE FOLLOWING INFORMATION IS TO BE VERIFIED.

#### OVERHEAD OBSTRUCTIONS

THE AREA WHERE THE LIFT WILL BE LOCATED SHALL BE FREE OF OBSTRUCTIONS. HEATERS, BUILDING SUPPORTS, ELECTRICAL CONDUIT; ALL OF THESE ITEMS ARE TO BE TWELVE FEET ABOVE THE BAY FLOOR. REFER TO FIGURE 2 & 10.

#### DEFECTIVE CONCRETE

VISUALLY INSPECT THE BAY FLOOR AREA. THE UNIT CANNOT BE INSTALLED ON EXPANSION SEAMS, OR CONCRETE THAT IS CRACKED. THE UNIT IS ONLY AS STRONG AS THE FLOOR IT IS INSTALLED ON.

#### FLOOR REQUIREMENTS

THIS INFORMATION IS IN THE GENERAL FLOOR REQUIREMENTS. IF THE BAY FLOOR DOES NOT CONFORM TO THESE SPECIFICATIONS, REFER TO THE "NEW SLAB RECOMMENDATIONS" SECTION IN THIS MANUAL. REFER TO FIGURE 1.

LOCATE THE MAIN SIDE POST ON THE HIGH SIDE OF THE FLOOR IF A SLOPE IS NOTED. REFER TO FIGURE 11.

#### POWER SUPPLY

THE STANDARD POWER UNIT IS 220-VOLT SINGLE PHASE. REFER TO THE POWER UNIT SPECIFICATIONS SECTION. REQUIREMENTS MAY VARY ON SPECIAL ORDERS.

THE MAIN SIDE POST WILL REQUIRE THE POWER SUPPLY FOR THE UNIT. NOTE THE LOCATION OF THE POWER SUPPLY.

#### BAY SIZE

TO OPTIMIZE SHOP SPACE, IT IS ADVISED TO LOCATE A VEHICLE IN THE BAY PRIOR TO LAYOUT. NOTE WALKWAY'S OVERHEAD OBSTRUCTIONS, AND ABILITY TO MOVE EQUIPMENT IN THE BAY AREA. REFER TO FIGURE 2 & 10.

REQUIREMENTS MAY VARY ON SPECIAL ORDERS.

#### SPECIFICATIONS

REFERENCE ALL SPECIFICATIONS PRIOR TO INSTALLING A LIFT.

### WARNING

#### BEFORE DRILLING THE MOUNTING HOLES

- ALL ANCHORS MUST BE A MINIMUM OF 6 INCHES AWAY FROM ANY EXPANSION SEAMS, CONTROL JOINTS, OR OTHER INCONSISTENCIES IN THE CONCRETE. REFER TO ANCHOR MANUFACTURER SPECIFICATIONS FOR SPECIFIC INFORMATION CONCERNING EDGE DISTANCES AND BOLT TO BOLT DISTANCE REQUIREMENTS. REFER TO FIGURES 4, 5, & 6..
- REFERENCE ALL FIGURES PERTAINING TO DRILLING, WEJ-IT WARNINGS, AND INSTALLATION INSTRUCTIONS. REFER TO FIGURES 4, 5 & 6..
- CHECK THE INSIDE DIMENSIONS OF THE POST AT THE BOTTOM FROM THE FACE OF THE MAIN SIDE POST TO THE FACE OF THE OFF SIDE POST. THE INSIDE DIMENSION IS 91-3/4 INCHES.
- USE A SHARP DRILL BIT TO PREVENT DRILLING AN UNDERSIZED HOLE. DRILL THE HOLE EQUAL TO THE LENGTH OF THE WEJ-IT ANCHOR. BLOW OUT THE HOLE WITH SHOP AIR, OR VACUUM. INSERT THE WEJ-IT ANCHOR SO THAT THE WASHER RESTS AGAINST THE POST FOOTING.
- NEVER USE AN IMPACT TOOL TO TIGHTEN THE WEJ-IT ANCHORS. USE A TORQUE WRENCH ONLY.
- MAKE SURE THE CONCRETE IS SOLID WHEN DRILLING. CRACKS AND EXPANSION SEAMS REDUCE THE EFFECTIVENESS OF THE WEJ-IT ANCHOR. NEVER INSTALL THE ANCHOR UNDER THESE CONDITIONS.
- DRILL SEVEN 3/4-INCH HOLES ON THE OUTSIDE OF THE MAIN SIDE POST USING THE HOLES AT THE BASE OF THE POST AS A GUIDE. INSERT AND TIGHTEN WEJ-IT ANCHORS PER SPECS LOCATED IN THE BACK OF THIS MANUAL.
- INSURE THE INSIDE DIMENSIONS BETWEEN THE MAIN AND OFF SIDE POST IS STILL CORRECT. 91-3/4 INCHES.
- DRILL SEVEN 3/4-INCH HOLES ON THE OUTSIDE OF THE OFF SIDE POST USING THE HOLES AT THE BASE OF THE POST AS A GUIDE. INSERT AND TIGHTEN WEJ-IT ANCHORS PER SPECS LOCATED IN THE BACK OF THIS MANUAL.

## INSTALLATION INSTRUCTIONS

### IMPORTANT

READ THIS MANUAL IN ITS ENTIRETY. BE FAMILIAR WITH PART NAMES AND HAVE A GOOD UNDERSTANDING OF HOW THIS UNIT IS TO BE ASSEMBLED AND OF HOW INDIVIDUAL PARTS OPERATE, BEFORE ASSEMBLING THE UNIT.

REFER TO ANSI/ALI ALIS, SAFETY REQUIREMENTS FOR INSTALLATION AND SERVICE OF AUTOMOTIVE LIFTS.

USING A CHALK LINE, LAYOUT THE FLOOR DIMENSIONS WHERE THE UNIT WILL BE LOCATED. **SEE FIGURE 2 & 10.**

CUT THE SWING ARM BANDING AND REMOVE THE SWING ARMS.

SECURE THE OVERHEAD LIFTING DEVICE TO THE MAIN SIDE POST USING STRAPS OR CHAINS.

### WARNING

- EACH POST WEIGHS OVER 800 LBS. ERECT THE POSTS WITH CHAINS AND STRAPS ATTACHED TO THE TOP OF THE POST. DO NOT REMOVE THE CHAINS AND STRAPS UNTIL THE POST HAS BEEN SECURED.

SEPARATE THE POSTS. REMOVE THE PARTS BOX, HYDRAULIC LINES AND SUPPORTS. VERIFY PARTS BOX CONTENTS. IF MISSING PARTS ARE NOTED, THEY CAN BE OBTAINED BY CALLING 1-800-833-2006 OR BY CONTACTING YOUR LOCAL MOHAWK DISTRIBUTOR.

USING THE 5/8-INCH PACKING BOLTS, NUTS AND WASHERS, ASSEMBLE THE CARRIAGE STOPS TO THE TOP OF THE MAIN SIDE POST. TIGHTEN TO 150 FOOT POUNDS. **SEE FIGURE 3.**

ERECT THE MAIN AND OFF SIDE POSTS TO THE UP-RIGHT POSITION. ALIGN THE POST FOOTINGS TO THE CHALK LINE LAYOUTS.

SECURE THE MAIN AND OFF SIDE POSTS TO THE BAY FLOOR USING THE (14) 3/4 X 5 1/2 INCH WEJ-IT ANCHORS. REFER TO "BEFORE DRILLING THE MOUNTING HOLES" SECTION.

USING THE 5/8-INCH PACKING BOLTS, NUTS AND WASHERS, ASSEMBLE THE CARRIAGE STOPS TO THE TOP OF THE OFF SIDE POST. TIGHTEN TO 150 FOOT POUNDS. **SEE FIGURE 3.**

ASSEMBLE THE TWO OVERHEAD HYDRAULIC LINES (FLAT ON THE FLOOR) USING THE FOUR DOUBLE MALE UNIONS.

ASSEMBLE TWO OF THE DOUBLE LINE CLIPS TO THE CENTER SPAN OF THE OVERHEAD LINES APPROXIMATELY 3 INCHES FROM THE DOUBLE UNIONS.

### NOTE

- THE 88 IN LINE IS TO BE PLACED TO THE FRONT AND THE 89-1/2 IN LINE TO BE PLACED TO THE REAR

ASSEMBLE THE TWO OVERHEAD LINE SUPPORT BRACKETS TO THE TOP OF THE MAIN AND OFF SIDE POST.

ERECT THE OVERHEAD HYDRAULIC LINE ASSEMBLIES. ROUTE THE LINES THROUGH THE TOP OF EACH POST. ASSEMBLE THE LINES TO THE HYDRAULIC CONNECTIONS AT THE TOP OF EACH POST.

SECURE THE LINES TO THE OVERHEAD LINE SUPPORTS USING THE TWO DOUBLE LINE CLIPS.

REMOVE THE BREATHER PORT PLUG ON THE POWER UNITS RESERVOIR AND DISCARD.

VERIFY FLUID LEVEL. (1/2 IN. BELOW BREATHER PORT IN THE POWER UNIT RESERVOIR WHEN BOTH CYLINDERS ARE FULLY RETRACTED) INSTALL THE BREATHER CAP.

### AT THIS TIME HAVE A QUALIFIED ELECTRICIAN CONNECT THE POWER SUPPLY TO THE UNIT

ENGAGE THE UP BUTTON ON THE POWER UNIT AND RAISE THE CARRIAGES APPROX. 3 FEET, OR TO A HEIGHT SUITABLE FOR INSTALLING THE SWING ARMS.

LIFTING UP ON THE SWING ARM RESTRAINT. INSERT THE FOUR SWING ARMS INTO THE CARRIAGES.

ALIGN THE THROUGH HOLES IN THE CARRIAGES WITH THE THROUGH HOLES IN THE SWING ARMS. SECURE THE SWING ARMS TO THE CARRIAGES USING THE FOUR SWING ARM PINS AND EIGHT SNAP RINGS.

PLACE THE FOUR LIFTING PADS INTO PLACE IN THE MOUNTING HOLE AT THE END OF EACH SLIDER.

### SHIMMING FOR CHAIN TENSION

LIFT UP ON THE YOKE, MEASURE THE SPACE BETWEEN THE TOP OF THE CHROME ROD AND THE BASE OF THE YOKE. THIS WILL BE THE AMOUNT OF SHIMS REQUIRED. **SEE FIGURE 9.**

TO SHIM, MANUALLY LIFT THE CARRIAGE ONE-FOOT APPROX. AND LOWER THE CARRIAGE ONTO THE MECHANICAL SAFETY.

### WARNING

- VISUALLY VERIFY SAFETY ENGAGEMENT BEFORE PROCEEDING.

PLACE THE CORRECT NUMBER OF SHIMS ON THE TOP OF THE CHROME ROD AND RE-INSTALL THE YOKE.

## INSTALLATION INSTRUCTIONS

### **BLEEDING PROCEDURE**

ENGAGE THE UP BUTTON ON THE POWER UNIT. OBSERVE THE CARRIAGE. WHEN THE MAIN AND OFF SIDE CARRIAGES HAVE REACHED FULL HEIGHT CONTINUE TO RUN THE UNIT FOR TWO MINUTES. (THIS WILL PURGE THE AIR FROM THE HYDRAULIC SYSTEM)

#### **NOTE**

- LISTEN FOR THE PRESSURE RELIEF VALVE. A NOTICEABLE INCREASE IN POWER UNIT VOLUME THIS WILL INDICATE AN EXCESS OF SHIMS BENEATH THE YOKE ASSEMBLIES RESTRICTING THE MAIN OR OFF SIDE CYLINDERS FROM REACHING FULL STROKE. IF THIS OCCURS, REMOVE ONE SHIM FROM BENEATH THE YOKE.

ASSEMBLE THE TWO HEIGHT ADAPTERS BRACKETS TO THE BACK OF THE MAIN AND OFF SIDE POST USING THE CYLINDER CLAMPS, WASHERS & NYLON LOCK NUTS.

PLACE THE FOUR 3 IN. AND FOUR 6 IN. HEIGHT ADAPTERS INTO PLACE INTO THE HEIGHT ADAPTER BRACKETS.

#### **SHIMMING THE POST**

LEVEL THE POST BY INSERTING THE SUPPLIED SHIMS UNDER THE POST FOOTING AROUND THE WEJ-IT ANCHOR. THE LIFT MUST BE LEVEL BOTH FRONT TO REAR AND SIDE TO SIDE. A LEVELING DEVICE AND A MEASURING TAPE MUST BE USED. **SEE FIGURE 7 & 8.**

- LEVEL THE MAIN SIDE POST FRONT TO REAR AND SIDE-TO-SIDE USING A BUBBLE LEVEL.
- LEVEL THE OFF SIDE POST FRONT TO REAR USING A BUBBLE LEVEL. SET THE POST PARALLEL TO THE MAIN SIDE POST USING A MEASURING TAPE, MEASURING FROM THE EDGE OF THE MAIN SIDE CHANNEL TO THE EDGE OF THE OFF SIDE CHANNEL AT THE BASE AND AT THE TOP OF THE POST.
- THE MEASUREMENT AT THE TOP OF THE POST MUST BE THE SAME AS THE MEASUREMENT AT THE BASE OF THE POST.

AT THIS TIME PERFORM THE PRE-OPERATION CHECK LIST AND MAINTENANCE PROCEDURES (DAILY - WEEKLY - MONTHLY) MAKE ALL ADJUSTMENTS PERTAINING TO THESE PROCEDURES.

### **DIVERTER VALVE OPERATION**

#### **WARNING**

AS WITH ALL FUNCTIONS OF THE LIFT UNIT, NEVER OPERATE THE DIVERTER VALVE UNLESS YOU HAVE FIRST PERFORMED THIS OPERATION WITH NO VEHICLE, AND FULLY UNDERSTAND ITS FUNCTIONS.

BOTH MECHANICAL SAFETIES MUST BE ENGAGED BEFORE OPERATING THE DIVERTER VALVE.

#### **PURPOSE**

- THE PURPOSE OF THE DIVERTER VALVE IS TO ENABLE THE OPERATOR TO RAISE OR LOWER THE OFF SIDE CARRIAGE INDEPENDENTLY OF THE MAIN SIDE CARRIAGE.

#### **TO OPERATE THE DIVERTER VALVE**

ENGAGE THE DIVERTER VALVE BY PULLING DOWN ON THE DIVERTER VALVE PULL KNOB.

- THIS WILL DIVERT ALL FUNCTIONS OF THE POWER UNIT TO THE OFF SIDE CYLINDER.

WITH THE VALVE ENGAGED, ENERGIZE THE POWER UNIT BY PUSHING THE UP BUTTON.

WHEN THE DESIRED HEIGHT HAS BEEN ACHIEVED, RELEASE THE DIVERTER VALVE PULL KNOB AND THE UP BUTTON.

PULLING DOWN ON THE LOWERING HANDLE, LOWER THE UNIT ONTO BOTH MECHANICAL SAFETIES ENDING THIS PROCEDURE.

## SAFETY TIPS

PLEASE POST THE **AUTOMOTIVE LIFT SAFETY TIPS CARD**, (A COPY IS INCLUDED IN THE PARTS BOX) WHERE THEY WILL BE CONSTANTLY REMINDED TO YOUR LIFT OPERATOR. FOR INFORMATION SPECIFIC TO THE LIFT, ALWAYS REFER TO THE MOHAWK MANUAL.

- |  |  |
|--|--|
| <ul style="list-style-type: none"> <li>• INSPECT YOUR LIFT DAILY. NEVER OPERATE IT IF IT MALFUNCTIONS OR IF IT HAS BROKEN OR DAMAGED PARTS. REPAIRS SHOULD BE MADE WITH ORIGINAL MOHAWK PARTS.</li> <li>• OPERATING CONTROLS ARE DESIGNED TO CLOSE WHEN RELEASED. DO NOT BLOCK OPEN OR OVERRIDE THEM.</li> <li>• NEVER OVERLOAD YOUR LIFT BEYOND STATED LIFTING CAPACITY. RATED CAPACITY IS SHOWN ON NAMEPLATE AFFIXED TO THE LIFT.</li> <li>• ONLY TRAINED AND AUTHORIZED PERSONNEL SHOULD DO POSITIONING OF VEHICLE AND OPERATION OF THE LIFT.</li> <li>• DO NOT ALLOW CUSTOMERS OR BY- STANDERS TO OPERATE THE LIFT OR TO BE IN A LIFTING AREA DURING ITS OPERATION. ONLY PROPERLY TRAINED PERSONNEL SHOULD BE ALLOWED TO OPERATE LIFT.</li> <li>• NEVER RAISE A VEHICLE WITH PERSONS INSIDE.</li> <li>• ALWAYS KEEP LIFT AREA FREE OF OBSTRUCTIONS, DEBRIS, GREASE, AND OIL.</li> <li>• PERFORM THE PRE-OPERATION CHECK LIST, PER INSTRUCTIONS, BEFORE RAISING VEHICLE TO DESIRED HEIGHT.</li> <li>• BEFORE DRIVING VEHICLE INTO THE BAY, POSITION ARMS AND SUPPORTS TO PROVIDE</li> </ul> | <p>UNOBSTRUCTED CLEARANCE. DO NOT HIT OR RUN OVER LIFT ARMS, ADAPTERS, OR AXLE SUPPORTS. THIS COULD DAMAGE LIFT OR VEHICLE.</p> <ul style="list-style-type: none"> <li>• LOAD VEHICLE ON LIFT CAREFULLY. POSITION LIFT SUPPORTS TO CONTACT AT THE VEHICLE MANUFACTURER'S RECOMMENDED LIFTING POINTS. RAISE LIFT UNTIL SUPPORTS CONTACT VEHICLE. CHECK SUPPORTS FOR SECURE CONTACT WITH VEHICLE. RAISE LIFT TO DESIRED WORKING HEIGHT. CAUTION: IF YOU ARE WORKING UNDER VEHICLE, LIFT SHOULD BE RAISED HIGH ENOUGH FOR LOCKING DEVICE TO BE ENGAGED.</li> <li>• NOTE THAT WITH SOME VEHICLES, THE REMOVAL OR INSTALLATION OF COMPONENTS MAY CAUSE A CRITICAL SHIFT IN THE CENTER OF GRAVITY, AND RESULT IN RAISED VEHICLE INSTABILITY. REFER TO THE VEHICLE MANUFACTURER'S SERVICE MANUAL FOR RECOMMENDED PROCEDURES WHEN VEHICLE COMPONENTS ARE REMOVED.</li> <li>• BEFORE LOWERING LIFT, BE SURE TOOL TRAY'S, STANDS, ETC. ARE REMOVED FROM UNDER VEHICLE. RELEASE LOCKING DEVICES BEFORE ATTEMPTING TO LOWER LIFT.</li> <li>• BEFORE REMOVING VEHICLE FROM THE LIFT AREA, POSITION LIFT ARMS AND SUPPORTS TO PROVIDE AN UNOBSTRUCTED EXIT.</li> </ul> |
|--|--|

## LIFT FINAL CHECKOUT (AFTER INSTALLATION):

REV (2/9/2006)

**THIS PROCEDURE OUTLINES THE FINAL CHECKS TO MAKE AFTER INITIAL INSTALLATION OF THE LIFT UNIT. REPEAT THIS PROCEDURE IF THE LIFT IS RELOCATED.**

**AFTER THE LIFT IS FULLY ASSEMBLED, RAISE THE LIFT EMPTY A FEW TIMES TO VERIFY:**

- PROPER SYNCHRONIZATION OF LIFT ARMS
- UNIT IS RAISING SMOOTHLY (AIR IS BLEED FROM HYDRAULIC SYSTEM - SEE BLEEDING PROCEDURE FOR MORE DETAILS)
- NO LEAKS PRESENT AT ANY FITTING JUNCTIONS
- LOCKS ARE ENGAGING ON BOTH POSTS AS LIFT IS RAISING
- LOCKS ARE DIS-ENGAGING ON BOTH POSTS WHEN RELEASE CABLE PULLED (SEE J-BAR ADJUSTMENT PROCEDURE)
- LOCKS ARE RE-ENGAGING AFTER DIS-ENGAGED WHEN LIFT IS RAISED
- LIFT IS NOT DRIFTING DOWN WHEN RAISED (RAISE LIFT, THEN STOP, AND VERIFY DRIFT DOWN OF CYLINDERS)
- NO VIBRATIONS FROM LOOSE CLAMPING, ETC.
- SWING ARMS ROTATE SMOOTHLY WHEN LIFT FULLY LOWERED AND LOCK IN PLACE WHEN LIFT RAISED

ONCE THIS IS COMPLETE, LOCATE A REPRESENTATIVE VEHICLE INTO THE LIFTING AREA. USE A VEHICLE THAT WEIGHS AT LEAST 75 PERCENT OF THE CAPACITY OF THE LIFT. OBSERVING LIFTING PROCEDURES CONTAINED IN THIS MANUAL TO LOCATE VEHICLE IN LIFTING AREA, AND TO LOCATE LIFTING PADS AT LIFTING POINTS FOR VEHICLE, AND WHILE RAISING AND LOWERING.

**RAISE LIFT APPROXIMATELY 1 FOOT. VERIFY THE FOLLOWING:**

- PROPER SYNCHRONIZATION OF LIFT ARMS
- NO EXCESSIVE DEFLECTION OF POSTS OR ARMS
- NO LOOSENING OF REAR ANCHOR BOLTS IN BASE PLATES AT FLOOR (LOOK FOR GAP BETWEEN FLOOR AND BASES)
- UNIT IS RAISING SMOOTHLY (AIR IS BLEED FROM HYDRAULIC SYSTEM - SEE BLEEDING PROCEDURE FOR MORE DETAILS)
- NO LEAKS PRESENT AT ANY FITTING JUNCTIONS
- LOCKS ARE ENGAGING ON BOTH POSTS AS LIFT IS RAISING
- LIFT IS NOT DRIFTING DOWN WHEN RAISED (RAISE LIFT, THEN STOP, AND VERIFY DRIFT DOWN OF CYLINDERS)
- NO VIBRATIONS FROM LOOSE CLAMPING, ETC.

**RELEASE LOCKS AND LOWER UNIT. VERIFY THE FOLLOWING:**

- PROPER SYNCHRONIZATION OF LIFT ARMS
- UNIT IS LOWERING SMOOTHLY (AIR IS BLEED FROM HYDRAULIC SYSTEM - SEE BLEEDING PROCEDURE FOR MORE DETAILS)
- NO LEAKS PRESENT AT ANY FITTING JUNCTIONS
- NO VIBRATIONS FROM LOOSE CLAMPING, ETC.
- LOCKS ARE NOT RE-ENGAGING WHILE LOWERING

**RAISE LIFT TO FULL STROKE. VERIFY THE FOLLOWING:**

- PROPER SYNCHRONIZATION OF LIFT ARMS
- NO EXCESSIVE DEFLECTION OF POSTS OR ARMS
- NO LOOSENING OF REAR ANCHOR BOLTS IN BASE PLATES AT FLOOR (LOOK FOR GAP BETWEEN FLOOR AND BASES)
- UNIT IS RAISING SMOOTHLY (AIR IS BLEED FROM HYDRAULIC SYSTEM - SEE BLEEDING PROCEDURE FOR MORE DETAILS)
- NO LEAKS PRESENT AT ANY FITTING JUNCTIONS
- LOCKS ARE ENGAGING ON BOTH POSTS AS LIFT IS RAISING
- LIFT IS NOT DRIFTING DOWN WHEN RAISED (RAISE LIFT, THEN STOP, AND VERIFY DRIFT DOWN OF CYLINDERS)
- NO VIBRATIONS FROM LOOSE CLAMPING, ETC.

**LOWER LIFT ONTO LOCKS. VERIFY THE FOLLOWING:**

- LOCK IS ENGAGING UPON DESCENT
- PROPER SYNCHRONIZATION OF LIFT ARMS

**RAISE, THEN RELEASE LOCKS, THEN LOWER VEHICLE TO FLOOR. VERIFY THE FOLLOWING:**

- PROPER SYNCHRONIZATION OF LIFT ARMS
- UNIT IS RAISING & LOWERING SMOOTHLY (AIR IS BLEED FROM HYDRAULIC SYSTEM - SEE BLEEDING PROCEDURE FOR MORE DETAILS)
- NO LEAKS PRESENT AT ANY FITTING JUNCTIONS
- NO VIBRATIONS FROM LOOSE CLAMPING, ETC.
- LOCKS ARE NOT RE-ENGAGING WHILE LOWERING
- NO LOOSENING OF REAR ANCHOR BOLTS IN BASE PLATES AT FLOOR (LOOK FOR GAP BETWEEN FLOOR AND BASES)

ENSURE THAT ALL MANUALS AND OTHER INSTRUCTIONAL MATERIALS ARE DELIVERED TO OWNER/USER/EMPLOYER. ENSURE THAT USERS ARE INSTRUCTED IN THE SAFE AND PROPER USER OF THE LIFT.

**FINAL CHECKOUT OF LIFT IS COMPLETE.**

**2-POST LIMITATIONS AND ADAPTER****USAGE:**  
**REV (2/9/2006)****2-POST LIMITATIONS:**

ALL MOHAWK 2-POST LIFTS ARE FOR INDOOR USE UNLESS SPECIFICALLY QUALIFIED AND MODIFIED FOR A CUSTOM ENVIRONMENT.

ALL MOHAWK 2-POST LIFTS MUST ACCOMPLISH THREE MAIN CRITERIA IN ORDER TO LIFT A VEHICLE SAFELY:

1. **PROPER FRAME ENGAGEMENT WITH PADS.** ALL 2-POST FRAME ENGAGING LIFTS ARE DESIGNED TO LIFT STANDARD VEHICLES WITHIN THEIR RATED CAPACITY BY THE VEHICLE FRAME. IF SUITABLE FRAME CONTACT LIFT POINTS CAN NOT BE REACHED OR ACCOMMODATED BY THE LIFTING PADS, THE VEHICLE MUST NOT BE RAISED WITH THE LIFT. REFER TO VEHICLE MANUFACTURER LIFTING POINT SPECIFICATIONS (AND VEHICLE LIFT POINT LABEL PER SAE J2184, VEHICLE LIFT POINTS FOR SERVICE GARAGE LIFTING).
2. **PROPER CENTER OF GRAVITY PLACEMENT OF VEHICLE ON LIFT** ENSURE THAT THE CENTER OF GRAVITY OF THE VEHICLE LIES CENTERED BETWEEN THE LIFTING ARMS. THIS SHOULD PLACE THE CENTER OF GRAVITY OF THE VEHICLE IN LINE WITH THE CENTER OF THE POSTS AS WELL.
3. **PROPER LOADING OF ARMS.** INDIVIDUAL ARM CAPACITIES ARE ¼ OF THE RATED LIFT CAPACITY, AND MUST NOT BE EXCEEDED. FOR INSTANCE, A 10,000 LB RATED 2-POST LIFT HAS ARMS THAT ARE RATED FOR 2,500 LBS EACH. IT IS POSSIBLE THAT A 10,000 LB VEHICLE CAN OVERLOAD THE ARMS ON A 10,000 LB LIFT IF THE FRONT AND REAR LOADING ARE NOT EQUAL.

WITH RESPECT TO HEAVY ENDED VEHICLES SUCH AS FORK TRUCKS, DELIVERY VANS, PICKUP TRUCKS, ETC, ATTENTION MUST BE MADE TO ENSURE THAT THE PER ARM CAPACITY OF THE LIFTING ARMS IS NOT EXCEEDED AND THAT THE CENTER OF GRAVITY OF THE VEHICLE LIES CENTERED BETWEEN THE LIFTING ARMS.

SPECIAL SAFETY PRECAUTIONS MUST BE OBSERVED IN APPLICATIONS INVOLVING VERY LONG AND VERY SHORT WHEELBASE VEHICLES. 2-POST LIFTS ARE NOT DESIGNED TO RAISE STRETCHED LIMOS AND OTHER TYPES OF LONG WHEEL BASE VEHICLES. AS A RULE OF THUMB, THE VEHICLE LENGTH ON A 2-POST MUST BE LIMITED TO 4 TIMES THE LENGTH OF THE ARM SPREAD TO RAISE IT. THE CENTER OF GRAVITY ON THIS VEHICLE MUST LIE BETWEEN THE LIFTING PADS TO ACCOMPLISH THIS. NOTE THAT SOME VEHICLES, PER VEHICLE MANUFACTURER GUIDELINES, ARE NOT TO BE RAISED BY THE FRAME. REFER TO VEHICLE MANUFACTURER GUIDELINES FOR PROPER LIFTING TECHNIQUES.

THIS LIFT IS NOT INTENDED, NOR DESIGNED, TO LIFT VEHICLE FRONT OR BACK ENDS USING ONLY TWO ARMS.

CARE MUST BE OBSERVED WHEN REMOVING ANY HEAVY COMPONENTS FROM A VEHICLE AND THEREBY DRASTICALLY SHIFTING THE VEHICLE CENTER OF GRAVITY (I.E. ENGINE REMOVAL, TRANSMISSION REMOVAL, ETC.). THE USE OF JACK STANDS AT THE FRONT AND REAR ENDS OF THE VEHICLE IS HIGHLY RECOMMENDED WHEN PERFORMING THIS TYPE OF WORK.

**ADAPTER USAGE AND LIMITATIONS:**

THE USE OF HEIGHT ADAPTERS IS COMMON FOR MOST LIFTING SITUATIONS TO ACCOMMODATE HIGH FRAMES AND LOW OVERHANGING BODIES OF VEHICLES.

FOR A-7, A-7A, SYSTEM IA, SYSTEM IA-10, TOMAHAWK-9000: THESE LIFTS COME STANDARD WITH (4) 3" AND (4) 6" HEIGHT ADAPTERS. THESE LIFTS ARE ONLY ALLOWED TO USE 2 ADAPTERS WHEN STACKED: ONE (1) 6" AND ONE (1) 3" ADAPTER, RESULTING IN 9" MAXIMUM STACKING HEIGHT. LONGER CUSTOM SINGLE PIECE ADAPTERS ARE AVAILABLE UPON REQUEST.

FOR LMF-12, TP-15, TP-16, TP-18, TP-20, TP-26, TP-30: THESE LIFTS COME STANDARD WITH (4) 5", (4) 7 ½", AND (4) 10" HEIGHT ADAPTERS. THESE LIFTS ARE ONLY ALLOWED TO USE 2 ADAPTERS WHEN STACKED: ONE (1) 10" AND ONE (1) 7½" ADAPTER, RESULTING IN 17 1/2" MAXIMUM STACKING HEIGHT. LONGER CUSTOM SINGLE PIECE ADAPTERS ARE AVAILABLE UPON REQUEST.

THE USER SHOULD BE WARNED THAT ANY SITUATION PRODUCING AN OFF-VERTICAL SLANTING OF THE HEIGHT ADAPTERS, SUCH AS DEFLECTION OF THE ARM DUE TO HEAVY LOAD, DEFLECTION OF THE ARM DUE TO SLOP, ECCENTRIC CORNER LOADING OF THE LIFT PAD, ETC. MUST BE AVOIDED. CUPPED OR YOKE STYLE LIFTING PADS (WHICH DO NOT RELY ON FRICTION) ARE ALSO AVAILABLE FOR SITUATIONS INVOLVING LIFTING NON-FLAT SURFACES. CONSULT MOHAWK SERVICE DEPARTMENT FOR CUSTOM PAD REQUESTS FOR YOUR APPLICATION.

**PRE - OPERATION CHECK LIST**

**TRAINED OPERATOR**

- THE OPERATOR MUST BE FULLY TRAINED AND QUALIFIED TO SAFELY AND EFFECTIVELY OPERATE THIS EQUIPMENT OF THIS SPECIFIC MAKE AND MODEL.

**ABSENCE OF OBSTRUCTIONS**

- THE TOTAL WORK AREA MUST BE FREE OF ANY AND ALL OBSTRUCTIONS AND BE GENERALLY CLEAN. (FREE OF OIL AND DEBRIS)

**VISUAL INSPECTION**

- THOROUGHLY INSPECT THE UNIT WITH A TRAINED EYE, NOTING ANY PROBLEM AREAS. INSPECT THE FLOOR AND THE ANCHORING FASTENERS AS WELL. REPORT ANY QUESTIONABLE ITEMS.

**NO LOAD PERFORMANCE CHECK**

- ALL MECHANICAL SAFETIES OPERATE PROPERLY AND CONSISTENTLY.
- NO EXTERNAL FLUID LEAKS.
- NO BLEED DOWN.
- EFFORTLESS AND SIMULTANEOUS MOVEMENT.
- LEVEL LIFTING.
- CONTROLS FUNCTION PROPERLY.
- ALL SAFETY MECHANISMS FULLY FUNCTIONAL.

**PREVIOUS DAY'S OPERATION REPORT**

- VERIFY WITH SUPERVISOR THAT THERE WAS NO PROBLEMS EXPERIENCED THE PREVIOUS DAY. IF THERE WERE ANY PROBLEMS, VERIFY THAT ALL NECESSARY REPAIRS HAVE BEEN COMPLETED.

**LIFTING PROCEDURES**

**LIFT PREPARATION AND VEHICLE POSITIONING**

- PERFORM PRE-OPERATION CHECK LIST ITEM BY ITEM.
- POSITION THE SWING ARM TO THE OUTSIDE OF THE UNIT.
- POSITION THE VEHICLE CENTERED BETWEEN THE POSTS.

**NOTE:**

ALIGN THE VEHICLE'S CENTER OF GRAVITY WITH THE OUTWARD CENTERLINE OF THE POSTS (DIRECTLY FROM THE GAGE OF THE CARRIAGES). PROPER POSITIONING CAN BE VERIFIED BY VIEWING THE CAM FOLLOWER BEARINGS ON THE CARRIAGE. THESE BEARINGS ARE LOCATED AT EACH CORNER OF THE CARRIAGE. CENTERING OF VEHICLE IS ACHIEVED WHEN ALL 4 CAM FOLLOWER BEARINGS ARE FREE TO SPIN.

- PLACE THE LIFTING PADS PER MFG'S RECOMMENDED LIFT POINTS FOR THE VEHICLE. REFER TO ALI/LP-GUIDE, ALI/SMO1-2 "LIFTING IF RIGHT" GUIDE, AND REFER TO THE RECOMMENDED LOCATION AND FORMAT OF THE VEHICLE LIFT POINT LABEL PER ANSI/SAE J2184-OCT92.

**CAUTION:**

IF PROPER AND SAFE LIFTING POINTS ON THE FRAME OF THE VEHICLE CAN NOT BE REACHED BY THE LIFTING PADS, DO NOT RAISE THE VEHICLE!

**TO RAISE**

- ENGAGE THE UP-BUTTON ON THE POWER UNIT.
- RAISE VEHICLE TO THE DESIRED WORKING HEIGHT.
- LOWER THE UNIT ONTO THE MECHANICAL SAFETIES.

**TO LOWER**

- INSPECT THE LIFTING AREA TO INSURE THAT ALL PERSONNEL AND DEBRIS HAVE BEEN CLEARED FROM THE LIFTING AREA.
- ENGAGE THE UP-BUTTON ON THE POWER UNIT.
- RAISE UNIT APPROXIMATELY TWO INCHES.
- DISENGAGE THE MECHANICAL SAFETIES.
- LOWER UNIT TO THE DESIRED WORKING HEIGHT.
- ALWAYS ENGAGE THE UP-BUTTON ON THE POWER UNIT AND RAISE UNIT UNTIL BOTH MECHANICAL SAFETIES RE-ENGAGE.
- LOWER THE UNIT ONTO THE MECHANICAL SAFETIES.
- IF WORK IS COMPLETE, CONTINUE LOWERING THE UNIT UNTIL BOTH CARRIAGES ARE FULLY LOWERED.

## MAINTENANCE PROCEDURES

-- TRAINED LIFT SERVICE PERSONNEL ONLY --  
REFER TO ANSI/ALI ALIS, SAFETY REQUIREMENTS  
FOR INSTALLATION AND SERVICE OF AUTOMOTIVE  
LIFTS.

### DAILY

- PERFORM THE PRE-OPERATION CHECK LIST.
- REPORT ANY AND ALL EQUIPMENT MALFUNCTIONS IMMEDIATELY.
- CLEAN ALL MOVING PARTS. (IT IS NOT RECOMMENDED TO GREASE THE INSIDE OF THE CHANNEL ON THE POST, SWING ARMS OR SWING ARM RESTRAINTS.) IF OXIDIZATION IS OCCURRING USE A LIGHT LUBRICANT. (WD - 40 OR EQUIVALENT)
- KEEP AREA AROUND THIS EQUIPMENT FREE OF DIRT, SAND, WATER, ETC.

### WEEKLY

- PERFORM THE DAILY OPERATION CHECK LIST.
- WIPE CLEAN, THE CYLINDERS' WIPER SEALS AND THE BASE OF EACH POST TO REMOVE ANY WEEPING OIL AND DUST.
- VERIFY FLUID LEVEL. WITH THE UNIT FULLY LOWERED, THE FLUID LEVEL WILL BE 1/2 INCH BELOW THE BREATHER CAP PORT. USE DEXRON III AS REPLACEMENT FLUID.
- LUBRICATE THE ARM RESTRAINT ASSEMBLIES AS NEEDED TO INSURE FREE, AND SMOOTH OPERATION. **(DO NOT USE GREASE)**
- CYCLE UNIT TO FULL HEIGHT, AND BLEED APPROXIMATELY 30 SECONDS.

### MONTHLY

- INSPECT LIFTING CHAINS AND COMPONENTS FOR DEFORMATION, WEAR OR CORROSION. SEE CHAIN INSPECTION AND MAINTENANCE PROCEDURE ON FOLLOWING PAGE.
- INSPECT SAFETY CABLE AND COMPONENTS FOR DEFORMATION, WEAR OR CORROSION. SEE CABLE INSPECTION AND MAINTENANCE PROCEDURE ON FOLLOWING PAGES.
- INSPECT ALL HYDRAULIC COMPONENTS FOR LEAKS, DEFORMATION, WEAR OR CORROSION.
- TIGHTEN ALL FASTENERS AND HYDRAULIC FITTINGS AS REQUIRED.
  1. ALL O - RING BOSS FITTINGS JAM NUTS ARE TO BE TIGHTENED TO 15-FOOT POUNDS TORQUE.
  2. ALL PIPE FITTINGS, IF LEAKING IS TO BE REMOVED, RE-SEALED, AND RE - INSTALLED. (SELECT - UNITE THREAD SEALANT OR EQUIVALENT ON FITTING THREADS)

- INSPECT ANCHOR CONDITIONS FOR ANY POSSIBLE CORROSION AND INSPECT THE FLOOR FOR ANY SIGNS OF FATIGUE OR FRACTURES.

### SEMI- ANNUAL TRAINING

- QUALIFY / RE-QUALIFY ALL PERSONNEL IN THE SAFE OPERATION OF THIS UNIT.
- VERIFY ALL FASTENERS TO PROPER TORQUE:
  - SWING ARM NUTS TO 1000 FT-LB
  - CARRIAGE STOP FASTENERS TO 170 FT-LB
  - CARRIAGE SIDE ROLLER NUTS TO 300 FT-LB
  - LIFTING ROD NUTS TO 720 FT-LB
  - CYLINDER TOP BOLT TO 720 FT-LB
  - ANCHORS (SEE ANCHOR SPECIFICATION SECTION)
- LUBRICATE LOCK BODY MAIN PIVOT PINS. REMOVE WITH SNAP RING PLIERS WHEN FULLY LOWERED AND CLEAN LOCK PIVOT PIN AND LOCK BODY HOLE. SPRAY PIN WITH A LIGHT LUBRICANT (WD-40 OR EQUIVALENT), THEN RE-ASSEMBLE, ENSURING SMOOTH MOTION.
- THE CHANNEL SECTIONS WHERE THE CARRIAGE BEARINGS RIDE AGAINST SHOULD BE CLEANED AND LUBRICATED USING A LIGHT LUBRICANT (WD-40).

THE MAIN CARRIAGE BEARINGS ARE FACTORY LUBRICATED AND DO NOT REQUIRE ANY ADDITIONAL PERIODIC LUBRICATION. HOWEVER, IF ADDITIONAL LUBRICATION IS DESIRED ON THESE UNDER THE CUSTOMER'S OWN INSPECTION AND MAINTENANCE PROGRAM, IT IS RECOMMENDED TO USE CAM2 – MULTIPURPOSE #2 GREASE (PART NO. 86035) OR EQUIVALENT. USE APPROXIMATELY 2 OZ. PER BEARING.

### ANNUALLY

- REPLACE AND RE-BLEED THE HYDRAULIC FLUID. ALWAYS USE A CLEAN FUNNEL AND FILTER. USE DEXRON III HYDRAULIC FLUID.
- INSPECT ALL BEARINGS FOR UNUSUAL OR EXCESSIVE WEAR. (REPLACE IF NEEDED)
- REMOVE THE SWING ARM RESTRAINTS. THOROUGHLY CLEAN. USE A LIGHT LUBRICANT (WD-40 OR EQUIVALENT) REINSTALL. **DO NOT USE GREASE.**
- REMOVE THE SWING ARMS. THOROUGHLY CLEAN. USE A LIGHT LUBRICANT (WD-40 OR EQUIVALENT) REINSTALL. **DO NOT USE GREASE.**
- REMOVE THE LIFTING CHAINS, THOROUGHLY CLEAN, LUBRICATE AND RE-INSTALL. (REPLACE IF UNUSUAL OR EXCESSIVE WEAR IS NOTED) SEE CHAIN INSPECTION AND MAINTENANCE PROCEDURE ON FOLLOWING PAGE.
- PERFORM THE DAILY, WEEKLY, AND MONTHLY MAINTENANCE PROCEDURES.

### PART REPLACEMENT NOTES

- REPLACE ALL WORN OR BROKEN PARTS WITH GENUINE LIFT MANUFACTURER SUPPLIED PARTS (FROM MOHAWK RESOURCES LTD. ONLY)
- ALL REPLACEMENTS OF PARTS ARE TO BE PERFORMED BY TRAINED LIFT SERVICE PERSONNEL ONLY.
- UPON PART REPLACEMENT, LIFT MUST PASS A FULL LIFT INSPECTION AS DEEMED SUITABLE BY TRAINED LIFT SERVICE PERSONNEL.

## CHAIN INSPECTION - MAINTENANCE PROCEDURES:

The following checks to be performed MONTHLY:

### Inspect for contamination.

Visually inspect chain for areas of dirt/debris and any areas showing evidence of rust/corrosion. If dirty, clean chain using a light lubricant (WD-40) - 0.5 oz. per foot by spraying.

### Inspect for corrosion.

If excessive rust or corrosion is witnessed, replace chain.

### Inspect chain link pins.

Visually inspect link pins for wear on both ends, ensuring that pins retain links. If any links are loose or worn, replace chain.

### Inspect chain links.

Inspect links for wear on surfaces in contact with yoke rollers. Inspect yoke rollers as well. If excessive wear is found, replace both chain and rollers.

### Inspect for excessive chain stretch.

Measure 16 pitches of chain while taut (see picture to right). Dimension should be no more than 12 1/4. If longer, replace chain.

**Note:** It is a rule-of-thumb that when the chain is replaced, the yoke rollers are replaced as well.

File: Man133.dwg

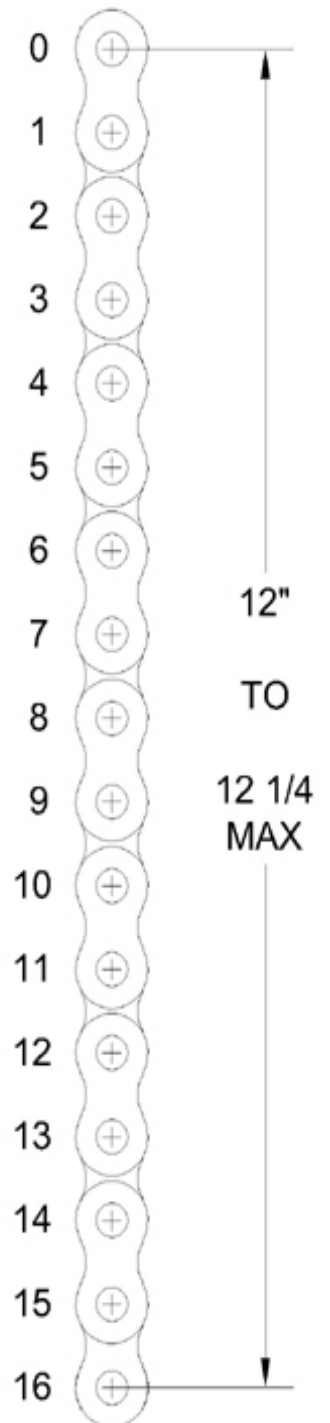

**CABLE MAINTENANCE & INSPECTION PROCEDURES:**

The cables found on this lift are non-load holding and are part of the slack chain device on this unit.

**WARNING:**

Failure to keep cables free of corrosive agents and solvents will lead to reduced service life and/or cable failure.

**Maintenance:** Cables should be kept free of corrosive agents, solvents, and road salts. If such agents are spilled or splashed onto cables, immediately rinse cables thoroughly with water, spray with WD-40 or equivalent, and wipe down with clean rag. Check these weekly.

**Inspections:**

1. Check cables for wear or damage. Any cable with broken wires, severe corrosion, excessive stretch, deformed strands, variations in diameter (necking), any change from normal appearance, or loose end crimps, must be replaced. If any area of the cable is found to be defective, the entire cable must be replaced. Refer to Figures 1, 2, 3, and 4 below:

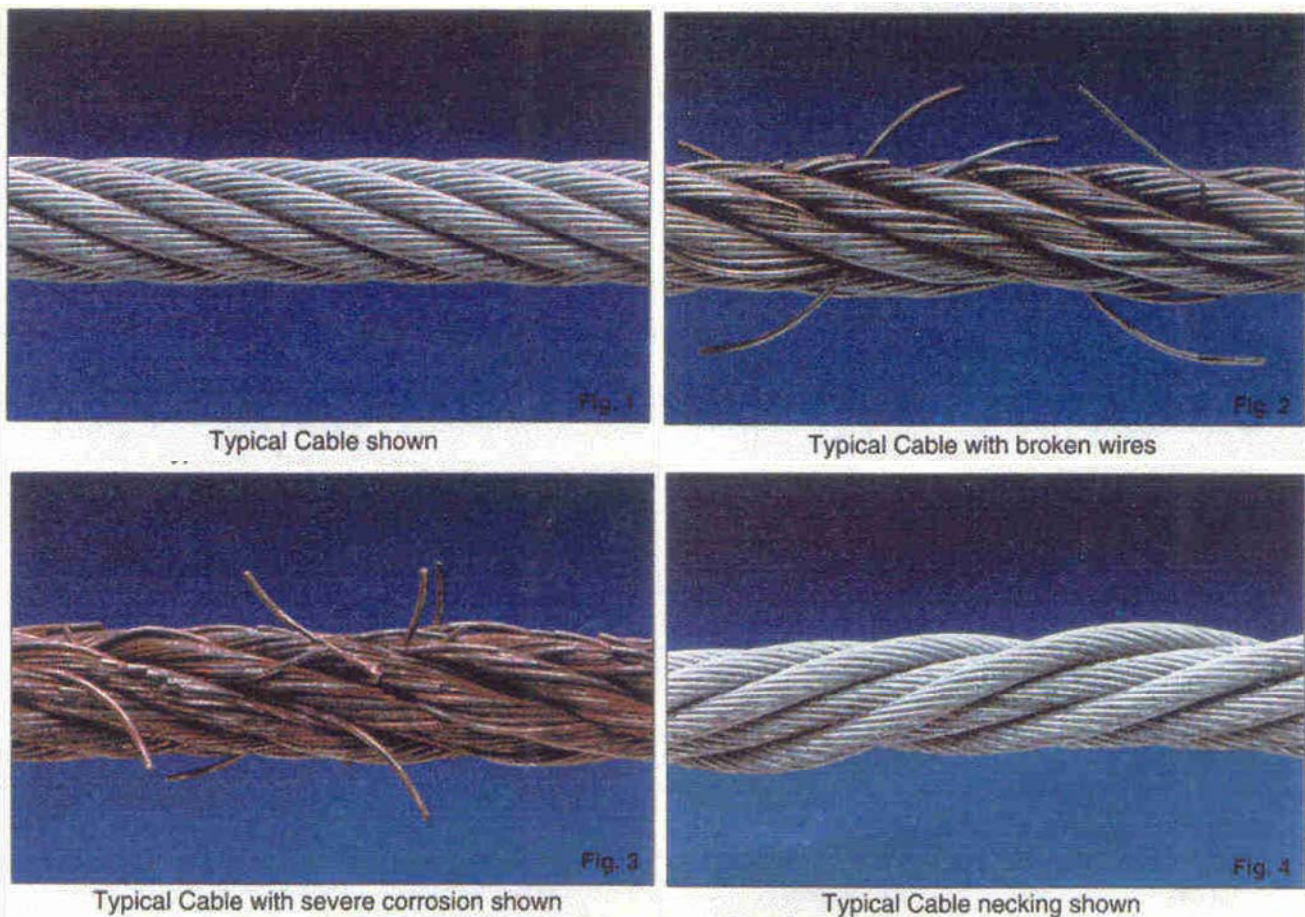

2. Check sheaves (pulleys) for wear or damage, i.e. wobble (tilt), cracks, loose on pin, or excessive noise during operation. Ensure that sheaves spin freely. Replace defective parts if found.

3. Check for loose or missing sheave (pulley) pins.

4. Watch locking latches and slack cable device during lift operation to ensure that latches engage and disengage properly.

**TROUBLE SHOOTING**

**WARNING:** NEVER ATTEMPT TO LOOSEN HYDRAULIC FITTINGS, OR OVERRIDE SAFETY DEVICES IN AN ATTEMPT TO CORRECT A PROBLEM. ALL TESTS ARE TO BE PERFORMED WITH **NO** VEHICLE.

**HYDRAULIC SAFETY CHECK**

NOTE: THE HYDRAULIC SAFETY CHECK IS TO BE PERFORMED WITH NO VEHICLE ON THE UNIT. CONTACT YOUR LOCAL MOHAWK DISTRIBUTOR OR THE MOHAWK FACTORY IF EITHER TEST FAILS.

**MAINSIDE SAFETY CHECK:**

1. RAISE THE UNIT APPROXIMATELY 3 FEET
2. DISENGAGE THE **OFFSIDE** MECHANICAL SAFETY
3. LOWER THE UNIT ONTO THE **MAINSIDE** MECHANICAL SAFETY
4. WHILE CONTINUING TO HOLD DOWN THE POWER UNIT LOWERING HANDLE, OBSERVE THE **OFFSIDE** CARRIAGE FOR MOVEMENT. THE UNIT HAS CHECK OUT OK IF THERE IS NO MOVEMENT (**OFFSIDE** CARRIAGE DOES NOT CONTINUE TO LOWER)

**OFFSIDE SAFETY CHECK:**

1. RAISE THE UNIT APPROXIMATELY 3 FEET
2. DISENGAGE THE **MAINSIDE** MECHANICAL SAFETY
3. LOWER THE UNIT ONTO THE **OFFSIDE** MECHANICAL SAFETY
4. WHILE CONTINUING TO HOLD DOWN THE POWER UNIT LOWERING HANDLE, OBSERVE THE **MAINSIDE** CARRIAGE FOR MOVEMENT. THE UNIT HAS CHECK OUT OK IF THERE IS NO MOVEMENT (**MAINSIDE** CARRIAGE DOES NOT CONTINUE TO LOWER)

POSSIBLE CAUSE	SOLUTION
<b>NOT RAISING LOAD</b>	
LOW HYDRAULIC FLUID LEVEL	LOWER UNIT. REMOVE RESERVOIR BREATHER CAP. FILL UNIT TO WITHIN 1/2 INCH BELOW PORT. USE DEXRON III TRANSMISSION / HYDRAULIC FLUID.
PRESSURE RELIEF ADJUSTMENT	CONTACT MOHAWK SERVICE DEPARTMENT.
PRESSURE RELIEF CONTAMINATION	REFER TO POWER UNIT SPECIFICATIONS. REMOVE AND CLEAN DEBRIS FROM VALVE ASSEMBLY. <b>SEE FIGURE 13.</b>
VOLTAGE TO POWER UNIT	REFER TO POWER UNIT SPECIFICATIONS. CONSULT AN ELECTRICIAN
UNIT OVERLOADED	VEHICLE IS TO HEAVY TO BE RAISED
<b>NOT LOWERING</b>	
MECHANICAL LOCKS ENGAGED	RAISE UNIT. DISENGAGE MECHANICAL LOCKS.
UNIT UNEVEN (SIDE TO SIDE)	RAISE UNIT TO FULL HEIGHT TO EQUALIZE. THEN LOWER OR USE DIVERTER VALVE TO EQUALIZE
POSTS OUT OF SQUARE	VERIFY LEVEL ASSEMBLY. MAKE ANY AND ALL NECESSARY ADJUSTMENTS. <b>SEE FIGURE 7 &amp; 8.</b>
DEBRIS IN POSTS (TOOLS ETC.)	CLEAN UNIT
OBSTRUCTION UNDER VEHICLE OR LIFT	REMOVE OBSTRUCTION.
<b>RAISING UNEVEN</b>	
<b><u>RULE OF THUMB:</u> IF THE MAIN SIDE IS HIGH, RUN UNIT TO FULL HEIGHT. IF THE MAIN SIDE IS LOW, LOWER UNIT TO FLOOR. ALLOW TIME FOR THE OFF SIDE TO EQUALIZE.</b>	
AIR IN SYSTEM	BLEED UNIT. REFER TO BLEEDING PROCEDURES.
CARRIAGE BEARINGS CONTACTING CARRIAGE STOPS	CARRIAGE BEARINGS ON THE MAIN SIDE MUST NOT CONTACT CARRIAGE STOPS. (RESULT OF INCORRECT CYLINDER SHIMS.) SEE "SHIMMING FOR CHAIN TENSION" SECTION. <b>SEE FIGURE 9.</b>
POSTS OUT OF SQUARE	VERIFY LEVEL ASSEMBLY. MAKE ANY AND ALL NECESSARY ADJUSTMENTS. <b>SEE FIGURE 7 &amp; 8..</b>
CYLINDER SHIMS	VERIFY CYLINDER SHIMS. MAKE ANY AND ALL NECESSARY ADJUSTMENTS. SEE "SHIMMING FOR CHAIN TENSION" SECTION. <b>SEE FIGURE 9.</b>
SHOP FLOOR UNEVEN	VERIFY PROPER INSTALLATION OF MAIN SIDE POST. MAIN SIDE TO BE ON HIGH SIDE. <b>SEE FIGURE 11.</b>

**TROUBLE SHOOTING, CONTINUED**

POSSIBLE CAUSE	SOLUTION
<b>RAISING UNEVEN, CONTINUED</b>	
SHOP FLOOR UNEVEN	USE SPECIAL LIFT PADS. <b>SEE FIGURE 12.</b>
DIVERTER VALVE	REMOVE BLEED LINE FROM THE TOP OF THE OFF SIDE CYLINDER AND CAP USING MOHAWK PART # 601-420-001. IF THE UNIT CONTINUES TO DRIFT DOWN THE DIVERTER PULL VALVE WILL NEED TO BE CLEANED OR REPLACED.
OFF SIDE CYLINDER	REMOVE BLEED LINE FROM THE TOP OF THE OFF SIDE CYLINDER AND CAP USING MOHAWK PART # 601-420-001. IF THE UNIT NO LONGER DRIFTS DOWN THE OFFSIDE CYLINDER WILL NEED TO BE SERVICED..
MAIN SIDE CYLINDER	PERFORM HYDRAULIC SAFETY CHECKS. CHECK FOR INTERNAL HYDRAULIC LEAKS
<b>SLOW DRIFT DOWN</b>	
SAFETIES NOT ENGAGED	RAISE UNIT TO RE-ENGAGE SAFETIES. THEN LOWER UNIT ONTO SAFETIES.
POWER UNIT LOWERING VALVE CONTAMINATION	BACK FLUSH POWER UNIT: PULL DOWN ON THE LOWERING HANDLE, AND THEN ENGAGE THE UP BUTTON AT THE SAME TIME. RUN UNIT APPROX. 10 SECONDS
DIVERTER VALVE	REMOVE BLEED LINE FROM THE TOP OF THE OFF SIDE CYLINDER AND CAP USING MOHAWK PART # 601-420-001. IF THE UNIT CONTINUES TO DRIFT DOWN THE DIVERTER PULL VALVE WILL NEED TO BE CLEANED OR REPLACED.
OFF SIDE CYLINDER	REMOVE BLEED LINE FROM THE TOP OF THE OFF SIDE CYLINDER AND CAP USING MOHAWK PART # 601-420-001. IF THE UNIT NO LONGER DRIFTS DOWN THE OFFSIDE CYLINDER WILL NEED TO BE SERVICED..
<b>EXTERNAL HYDRAULIC LEAKS</b> <b>NOTE: TIGHTEN ALL FITTINGS PER SPECIFICATIONS</b>	
MAIN SIDE CYLINDER	THOROUGHLY CLEAN THE CYLINDER. VERIFY LEAK ORIGIN. FITTINGS ARE TO BE TIGHTENED PER SPECIFICATIONS
OFF SIDE CYLINDER	THOROUGHLY CLEAN THE CYLINDER. VERIFY LEAK ORIGIN. FITTINGS ARE TO BE TIGHTENED PER SPECIFICATIONS.
BAD FLAIR OR FITTING	REMOVE THE HYDRAULIC LINE AND INSPECT FLAIR AND FITTING FOR DEFORMATION. REPLACE IF NEEDED.
BAD O-RING (O-RING TYPE FITTINGS)	CHANGE O-RING
LOOSE PIPE FITTING	REMOVE, RESEAL, AND RE-INSTALL FITTING. SEAL ALL PIPE FITTING CONNECTIONS WITH THREAD SEALANT MOHAWK PART # 601-610-002 NOTE: <b>DO NOT USE TEFLON TAPE.</b>
<b>MECHANICAL LOCK RE-ENGAGES</b>	
CHAIN BREAK SAFETY CABLE NEEDS ADJUSTMENT	TENSION IN CABLE MAY BE TO TIGHT. <b>REFER TO FIGURE 14.</b>
<b>MECHANICAL LOCK HARD TO PULL</b>	
CHAIN BREAK SAFETY CABLE NEEDS ADJUSTMENT	TENSION IN CABLE MAY BE TO TIGHT. <b>REFER TO FIGURE 14.</b>
FLIPPER STICKING ONTO LOCK BAR	APPLY A SMALL AMOUNT OF LUBRICANT TO THE LOCK BAR WHERE THE FLIPPER RIDES. (DO NOT USE HEAVY GREASE)



# MOHAWK

## MODEL A-7

### FIGURES & DIAGRAMS



## MOHAWK RESOURCES LTD.

65 VROOMAN AVE.

AMSTERDAM, NY 12010

**TOLL FREE:** 1-800-833-2006

**LOCAL:** 1-518-842-1431

**FAX:** 1-518-842-1289

**INTERNET:** [WWW.MOHAWKLIFTS.COM](http://WWW.MOHAWKLIFTS.COM)

**E-MAIN:** [SERVICE@MOHAWKLIFTS.COM](mailto:SERVICE@MOHAWKLIFTS.COM)

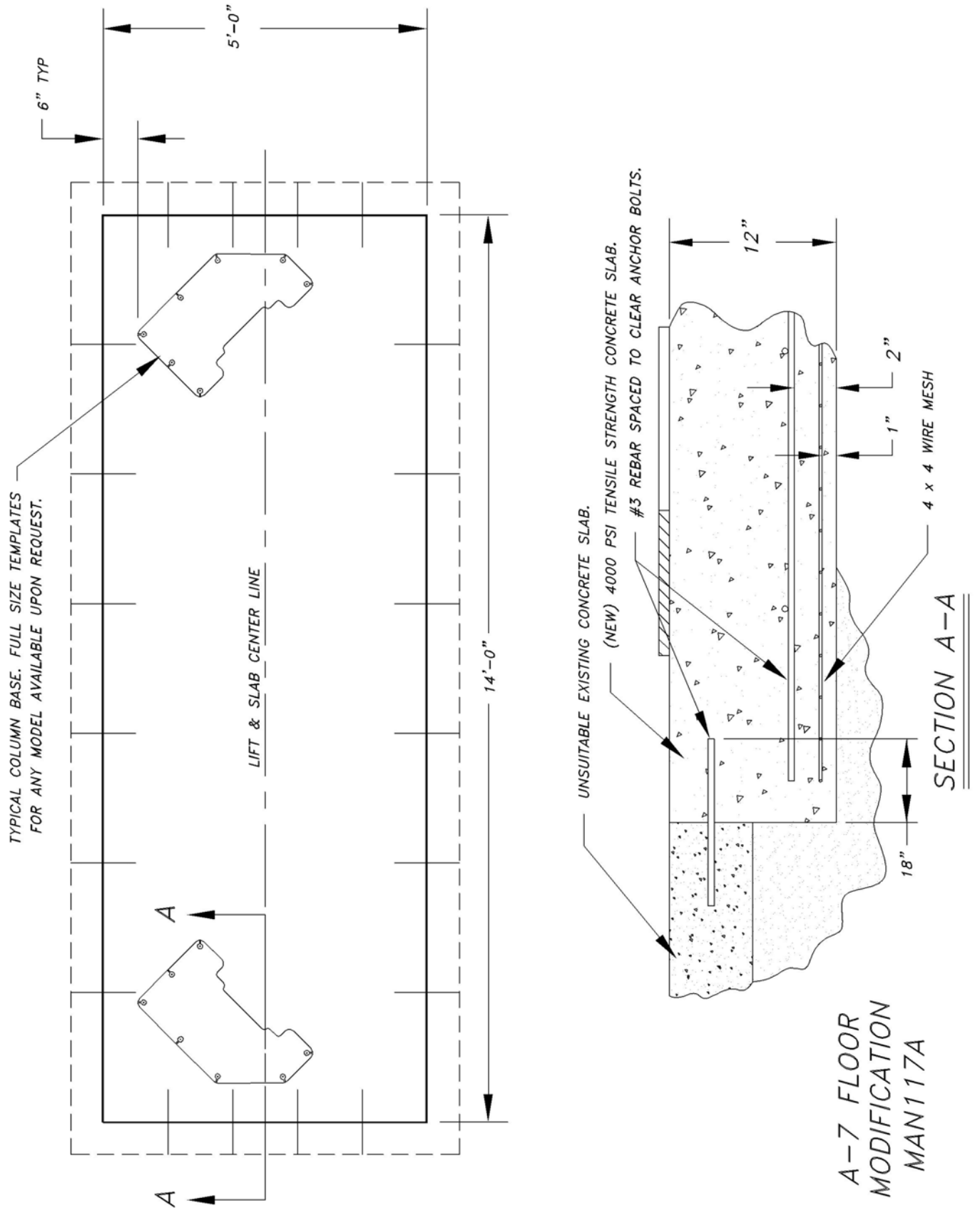
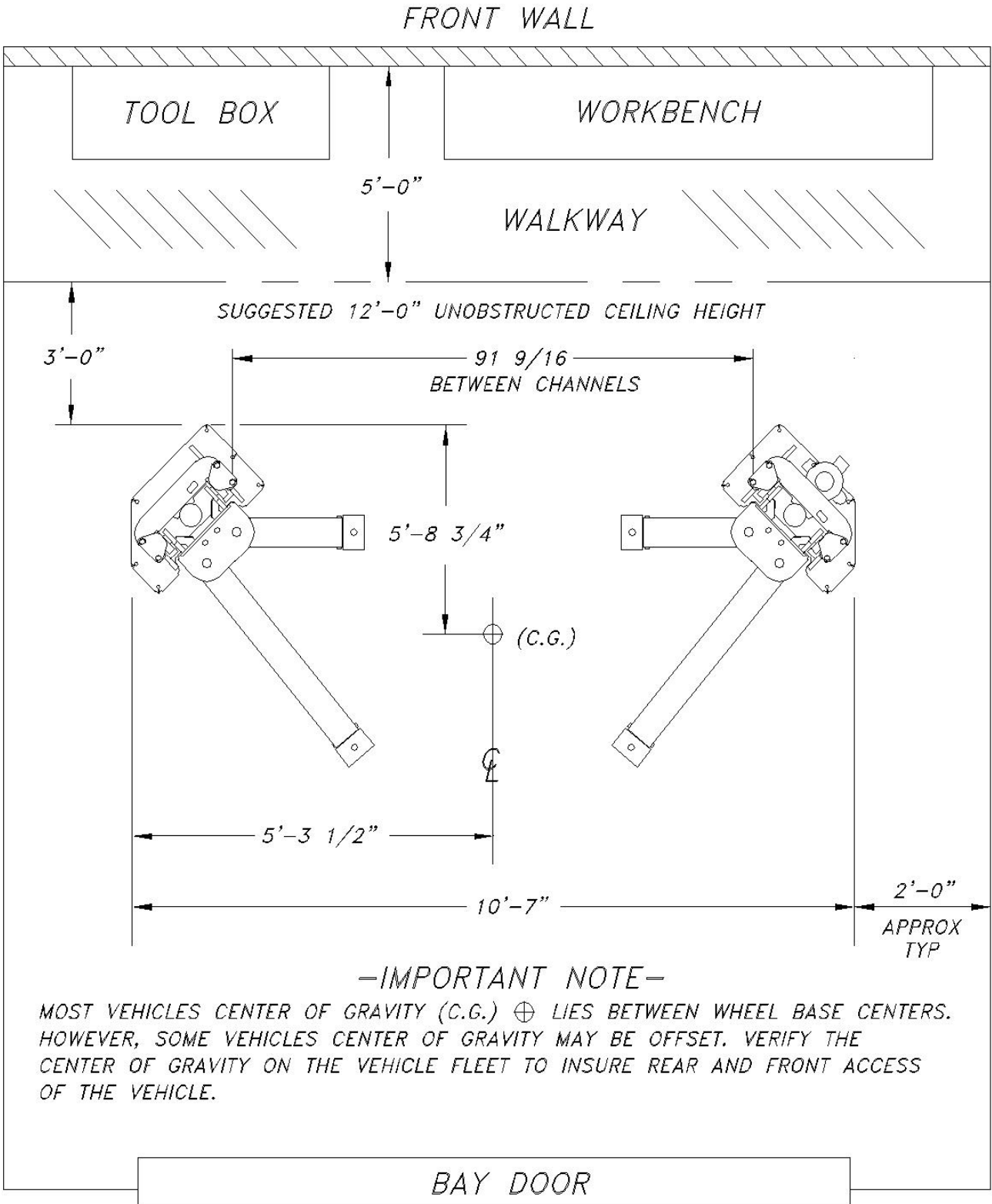

Figure 1

MOHAWK MODEL A-7  
 MOHAWK MODEL A-7  
 BAY SIGHT LAYOUT



MAN117E

Figure 2

**-CAUTION-**

THESE CARRIAGE STOPS ARE TO BE USED IN THE ASSEMBLY OF THIS LIFT. IT IS EXTREMELY IMPORTANT TO PLACE THESE IN THEIR DESIGNATED POSITION, WHICH IS SHOWN BELOW.

CARRIAGE STOP  
TYP. (4) PLACES

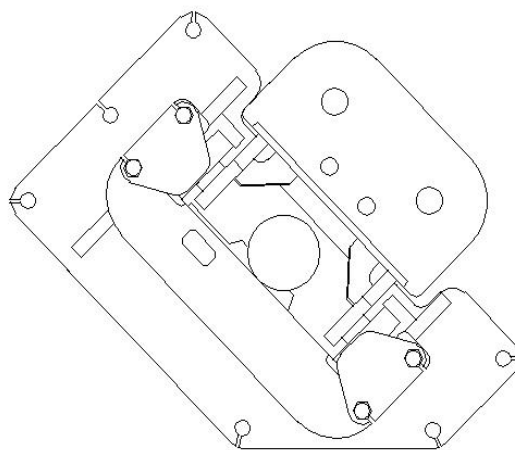

OFFSIDE

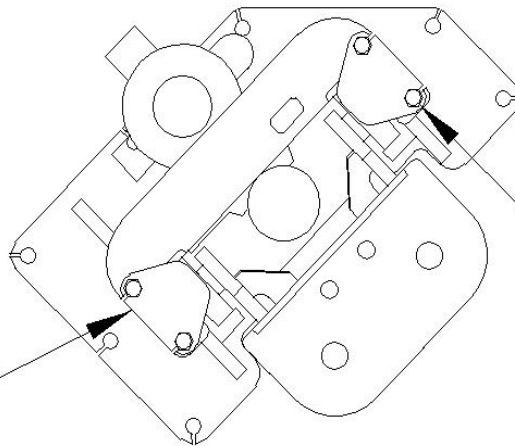

MAINSIDE

5/8-11NC BOLTS  
TYP. (8) PLACES  
TORQUE TO 150 FT-LBS

MAN117K

Figure 3

# WEJ-IT INSTALLATION

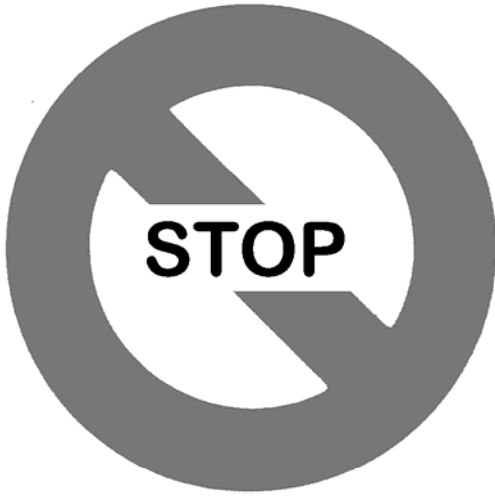

**DO NOT USE  
IMPACT WRENCH**

**USE HAND WRENCH ONLY**

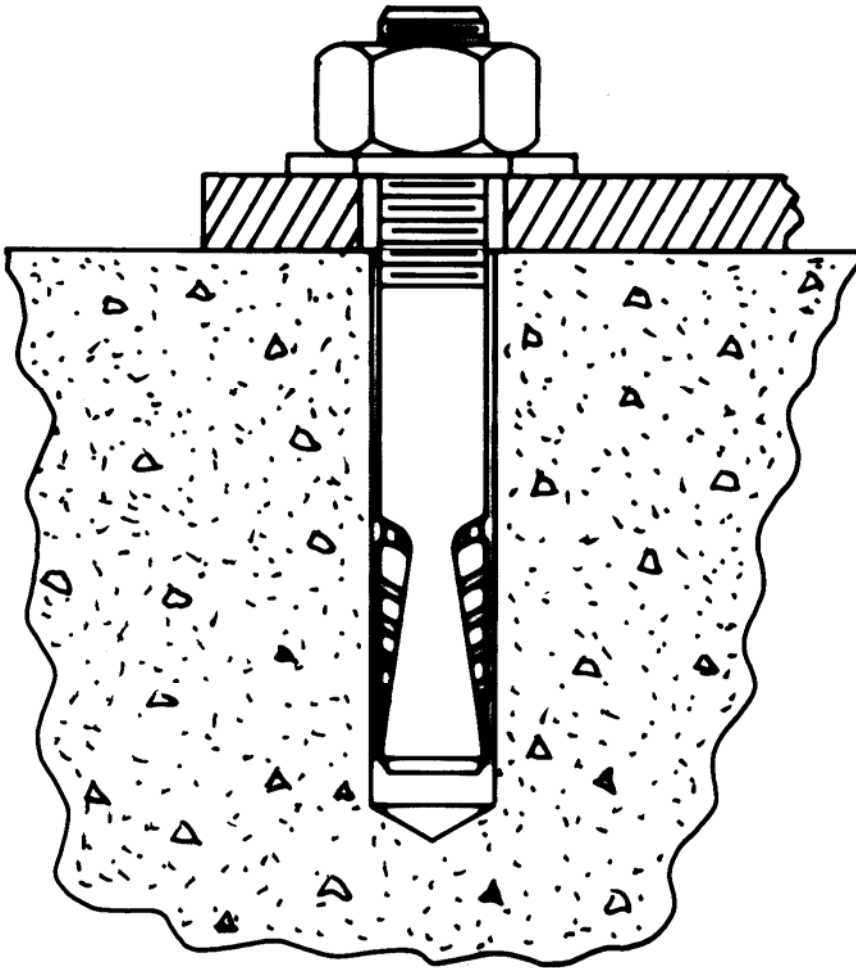
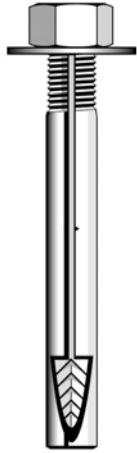

Figure 4

# The Original **wej-it**® Wedge Anchors



## KEY FEATURES/BENEFITS

- **Time-Tested, Proven Reliability.** An industry standard for over 45 years.
- **Fully Assembled and Ready to Use.** Unparalleled job-site convenience.
- **BOLT SIZE IS HOLE SIZE.®** Allows precision placement of equipment through pre-drilled holes.
- **Exclusive "Positive Wedge Connections."** Minimizes wedge loosening due to vibratory loads.



## SPECIFICATIONS, APPROVALS AND LISTINGS

TYPE	
Zinc Plating	ASTM B-633, Type III, SCl
ICBO-ES	Report #1821
City of Los Angeles	#RR 24939
DOT	Please call Customer Service for specific information by state.
Federal Specifications	QQZ-325C, Type II, Class 3 (Clear Chromate added) FFS-325, Group II, Type 4, Class 1

## MAXIMUM TENSILE AND SHEAR CAPACITY FOR STATIC LOADS

Anchor & Hole Size	LIMESTONE AGGREGATE			UNREINFORCED STONE AGGREGATE				CONCRETE				UNREINFORCED LIGHTWEIGHT (IDEALITE)		
	Embedment (in)	2000 psi Tension (lbs)	Shear (lbs)	Embedment (in)	3000 psi Tension (lbs)	Shear (lbs)	5000 psi Tension (lbs)	Shear (lbs)	7000 psi Tension (lbs)	Shear (lbs)	Embedment (in)	5000 psi Tension (lbs)	Shear (lbs)	
3/4	•	•	•	3	11579	15537	19299	21000	27019	23103	3 1/2	17293	19050	
3/4	•	•	•	7	15444	15537	25740	21000	36036	23103	•	•	•	
1	•	•	•	5 1/2	16351	•	27252	33083	38153	35700	4 1/2	21616	31666	
1	•	•	•	7	17837	•	29728	33083	41619	35700	•	•	•	
Source	1			2				2				2		

Sources (available upon request): 1) University of Texas, Austin, TX (using new ICBO-ES testing criteria); 1993. 2) AA Engineers & Associates, Inc., Denver, CO; 1981.

## LENGTH SELECTION GUIDE

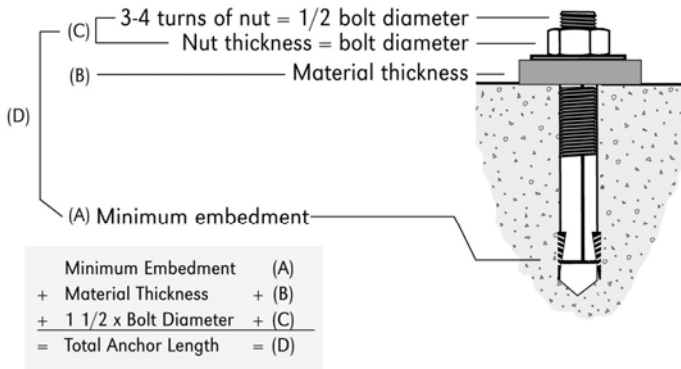

## EDGE DISTANCE AND SPACING REQUIREMENTS

Embedment (E) in Anchor Diameters (d)	Spacing	Edge Distance
E < 6d (shallow)	3.50E	1.75E
6d ≤ E ≤ 8d (standard)	2.00E	1.00E
8d < E (deep)	1.50E	0.75E

### NOTES:

- Information provided only for the use of a qualified design engineer. Use of technical data by persons not qualified could cause serious damage, injury, or even death.
- Ultimate values shown. For static loads, use one-fourth of the maximum tensile and shear capacities for the recommended 4:1 safety factor.

Figure 5

# INSTALLATION INSTRUCTIONS – MOHAWK LIFTS

1. Drill the hole perpendicular to the work surface.\* The drill bit diameter will be the same as the anchor diameter that you are installing. To assure full holding power, do not ream the hole or allow the drill to wobble. **Ensure all holes are a minimum of 6 inches away from any cracks, seams or defects in the concrete.**
2. Drill the hole 1 diameter deeper than the intended embedment of the anchor, but not closer than two diameters to the bottom (opposite) surface of the concrete.
3. Clean the hole using compressed air and a nylon brush. A clean hole is necessary for proper performance.
4. For ease of installation, make certain that the spear heads are located up against the wedge pockets.
5. Turn the nut onto the anchor until contact is made with the top of the spears and the bottom of the washer. Insert anchor into hole.
6. Tap anchor into hole with a 2 ½ lb. hammer until the washer rests solidly against the base plate.
7. Tighten the nut from 1 ½ to 3 turns past hand tight position to estimated installation torque below. Use of an Impact wrench for Installation of the anchor is NOT recommended.

## TORQUE VALUES

Anchor Diameter (in)	Drill Bit Diameter (in)	Estimated Install Torque (ft-lb)
3/4	3/4	75
1	1	130

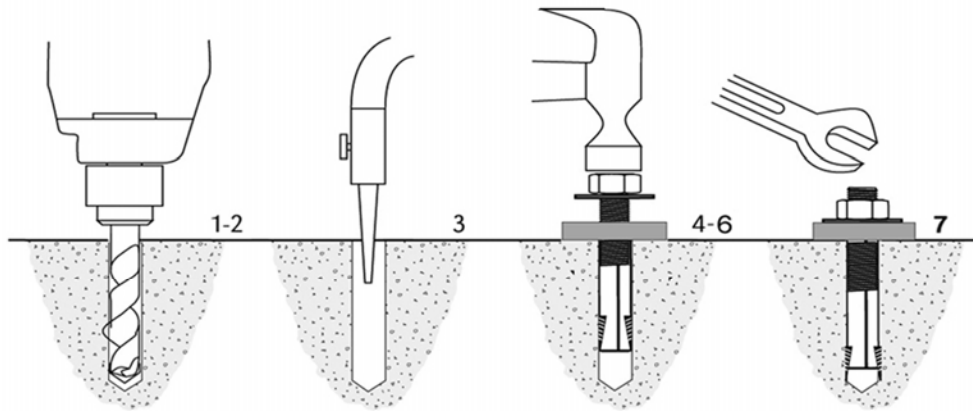

## INSPECTION & MAINTENANCE INSTRUCTIONS

1. Verify torque on anchors to 70 ft-lbs for 3/4 anchors and 120 ft-lbs for 1” anchors for future/annual inspections.
- \* Always wear safety glasses. Follow the drill manufacturer’s safety instructions. Use only solid carbide-tipped drill bits meeting ANSI B212.15 diameter standards as listed on back cover.

REV: 11/07

Figure 6

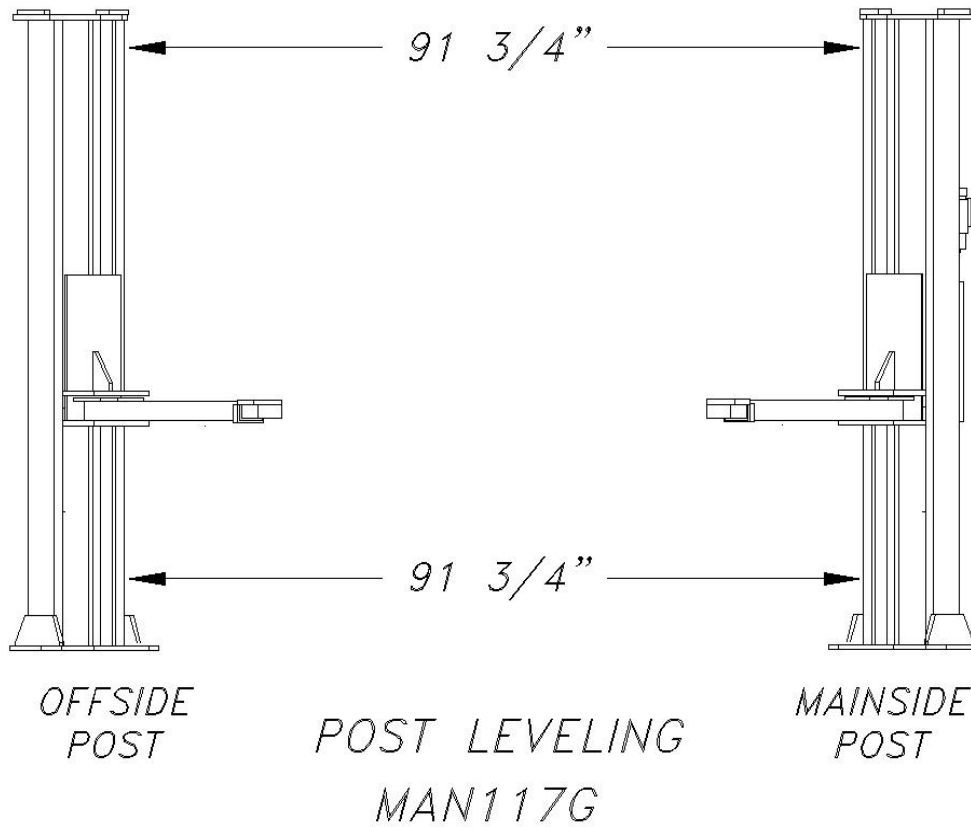
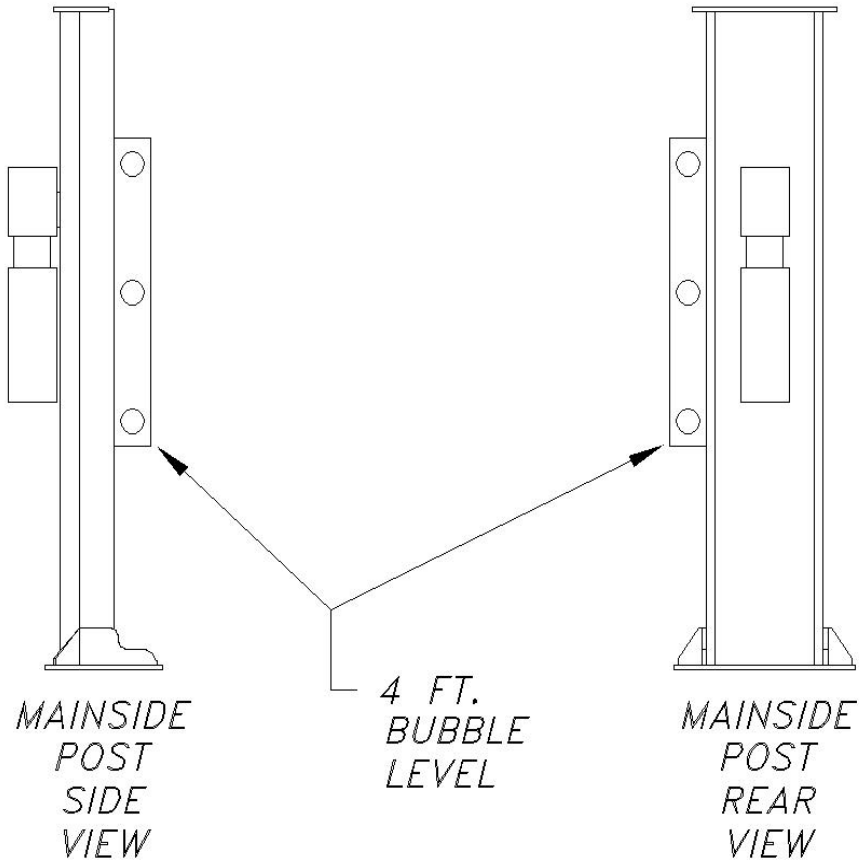
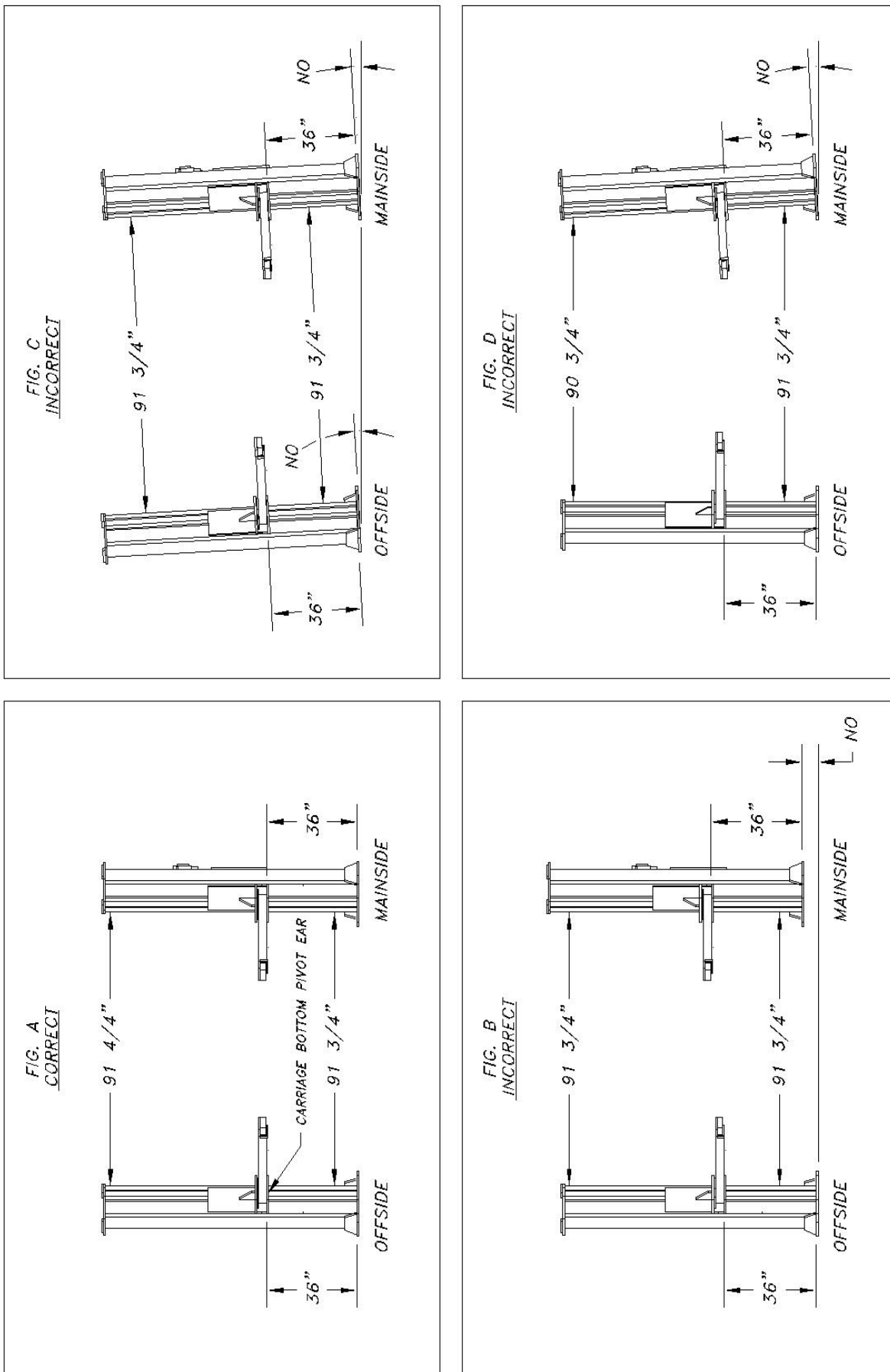

Figure 7



MAN117C

POST SHIMMING

Figure 8

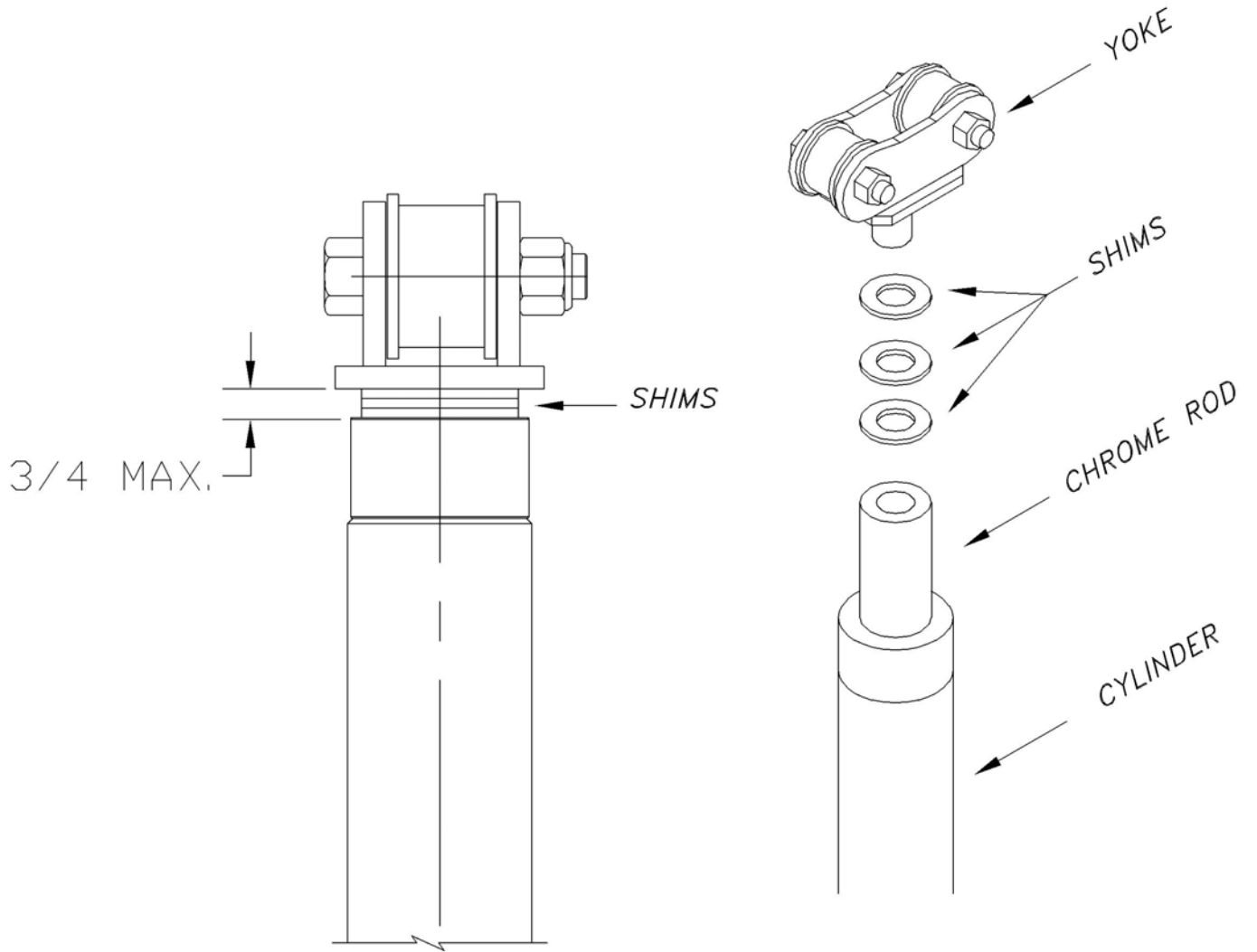

CYLINDER SHIMS

MAN117D

Figure 9

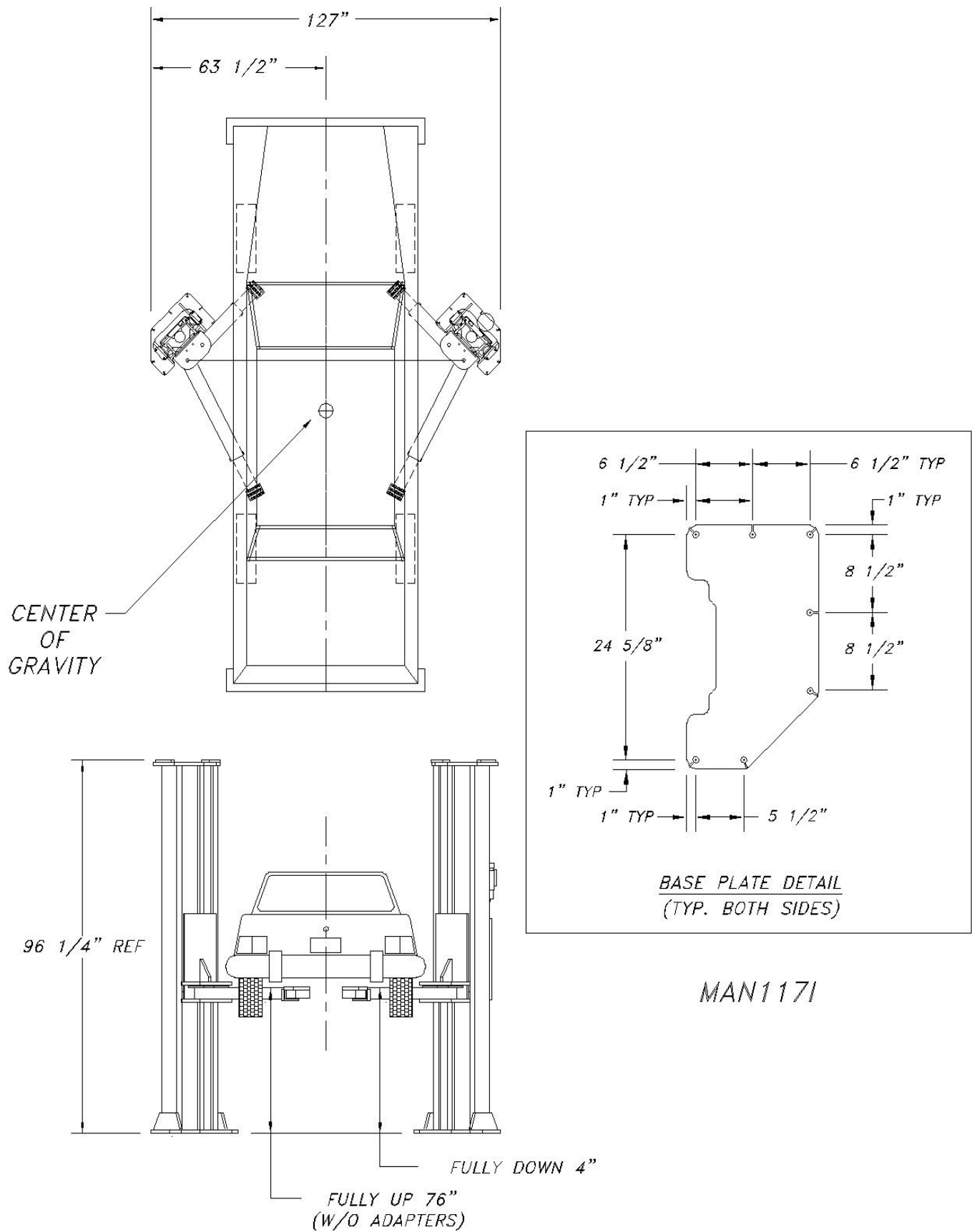

Figure 10

THE DIFFERENCE IN THE HEIGHT OF THE SWING ARMS IS NOTED ONLY AFTER THE CYLINDERS AND POSTS HAVE BEEN PROPERLY SHIMMED

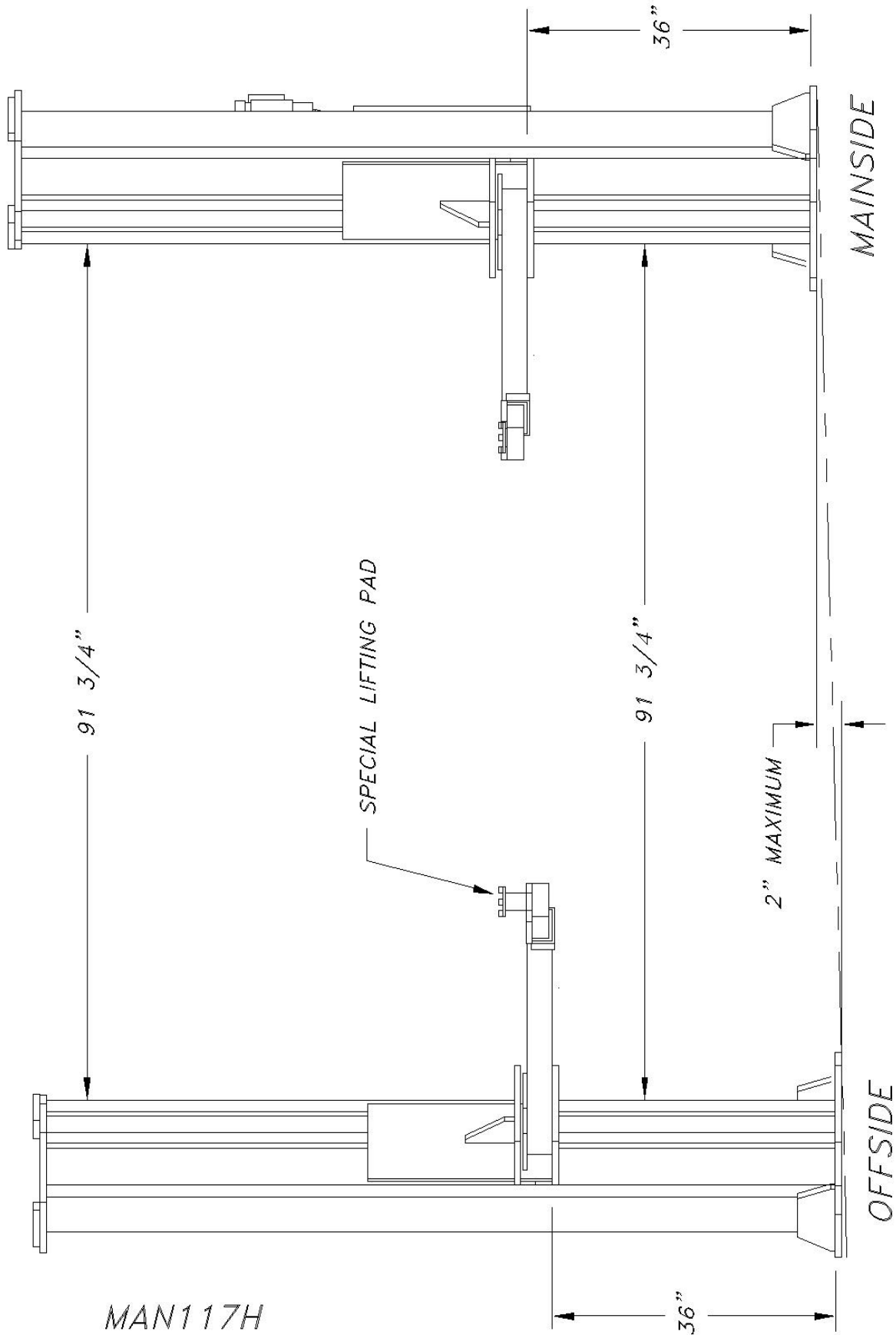
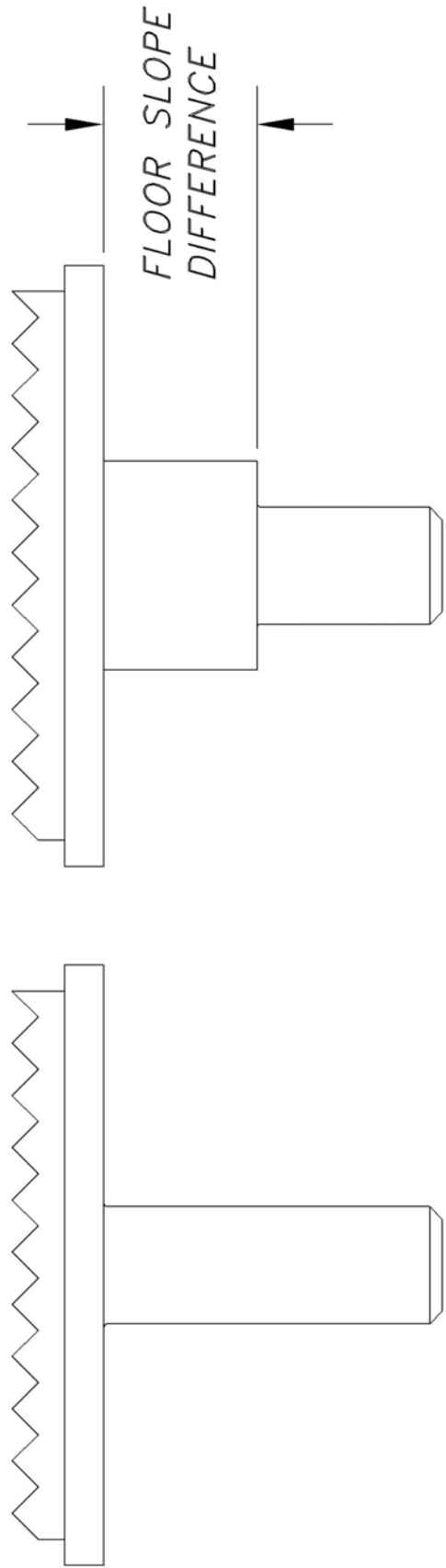

Figure 11



*SPECIAL LIFTING PAD*

*STANDARD LIFTING PAD*

*MAN117F*

**Figure 12**

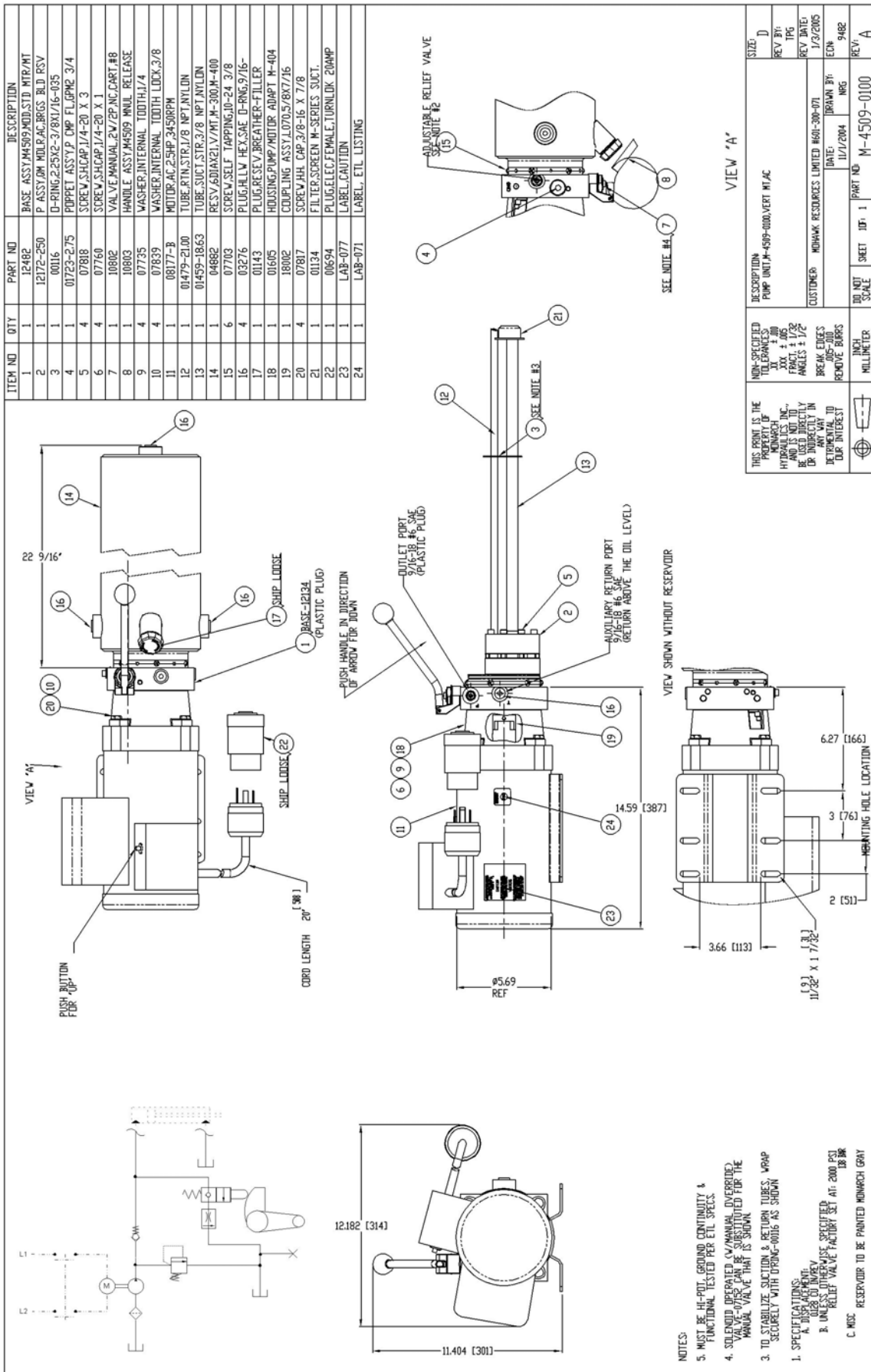

Figure 13

# CHAIN BREAK SAFETY SYSTEM:

MAN140.DWG

## FOR SERVICING, INSPECTING AND REPLACING CHAIN BREAK SAFETY CABLE:

1. ROUTE CHAIN BREAK SAFETY CABLE AS SHOWN.
2. PULL LOCK RELEASE CABLE AND VERIFY SLIGHT TENSION IN CABLE.
3. RAISE AND LOWER TO ENSURE THAT TENSION OF CABLE DOES NOT RE-ENGAGE LOCKS. ADJUST EYELET IN BACK OF POST AS REQUIRED.
4. REFER TO CABLE INSPECTION AND MAINTENANCE PROCEDURES. REPLACE ANY CABLE THAT DOES NOT MEET INSPECTION CRITERIA IMMEDIATELY.
5. **WARNING: DO NOT OPERATE THIS LIFT UNLESS THE CHAIN BREAK SAFETY CABLE IS PRESENT AND PERIODICALLY INSPECTED. FAILURE TO DO SO MAY COMPROMISE THE CHAIN BREAK SAFETY SYSTEM.**

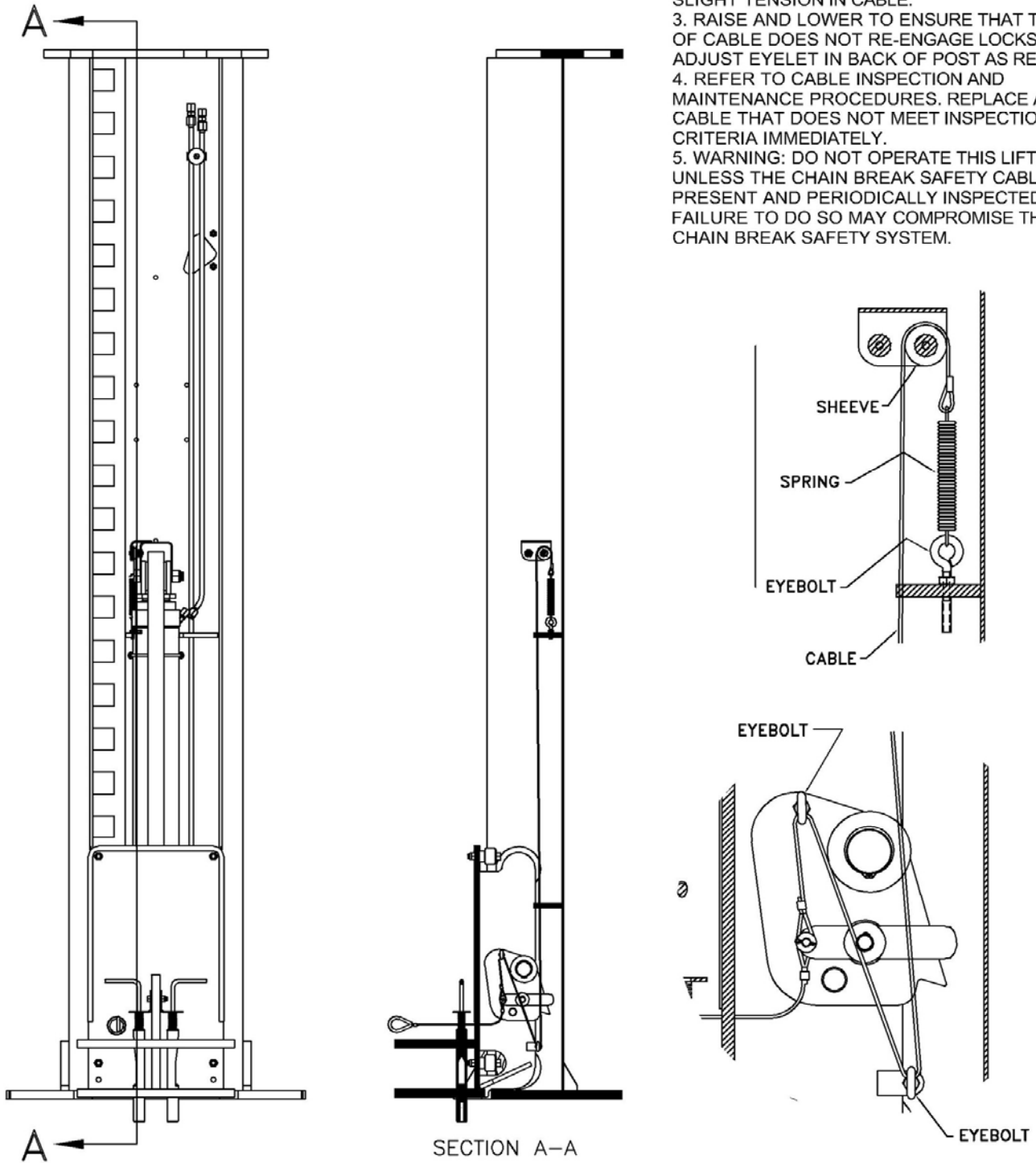

Figure 14

# **MOHAWK**

## **MODEL A-7**

### **PARTS MANUAL**



## **MOHAWK RESOURCES LTD.**

65 VROOMAN AVE.

AMSTERDAM, NY 12010

**TOLL FREE:** 1-800-833-2006

**LOCAL:** 1-518-842-1431

**FAX:** 1-518-842-1289

**INTERNET:** [WWW.MOHAWKLIFTS.COM](http://WWW.MOHAWKLIFTS.COM)

**E-MAIN:** [SERVICE@MOHAWKLIFTS.COM](mailto:SERVICE@MOHAWKLIFTS.COM)

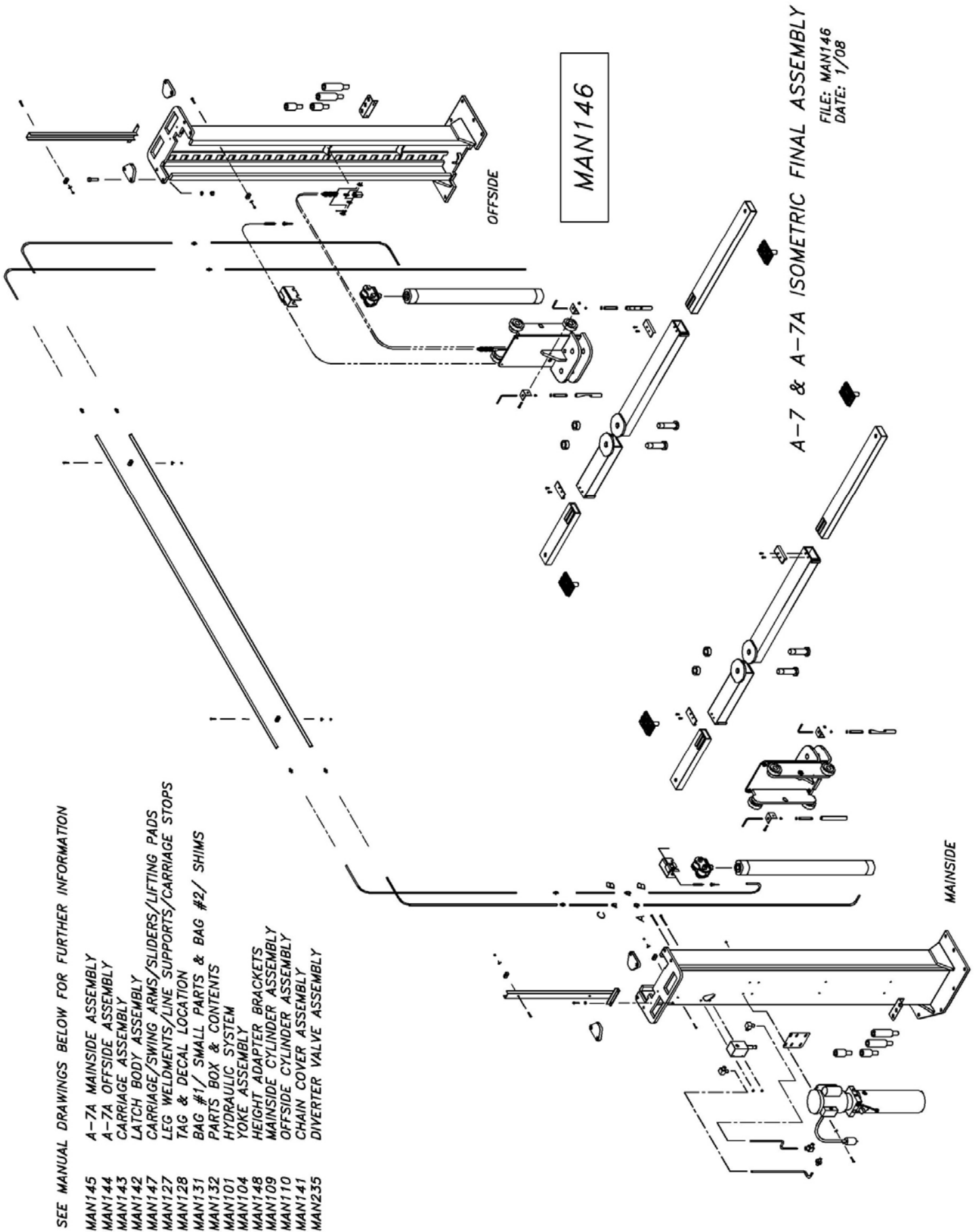

MAN145

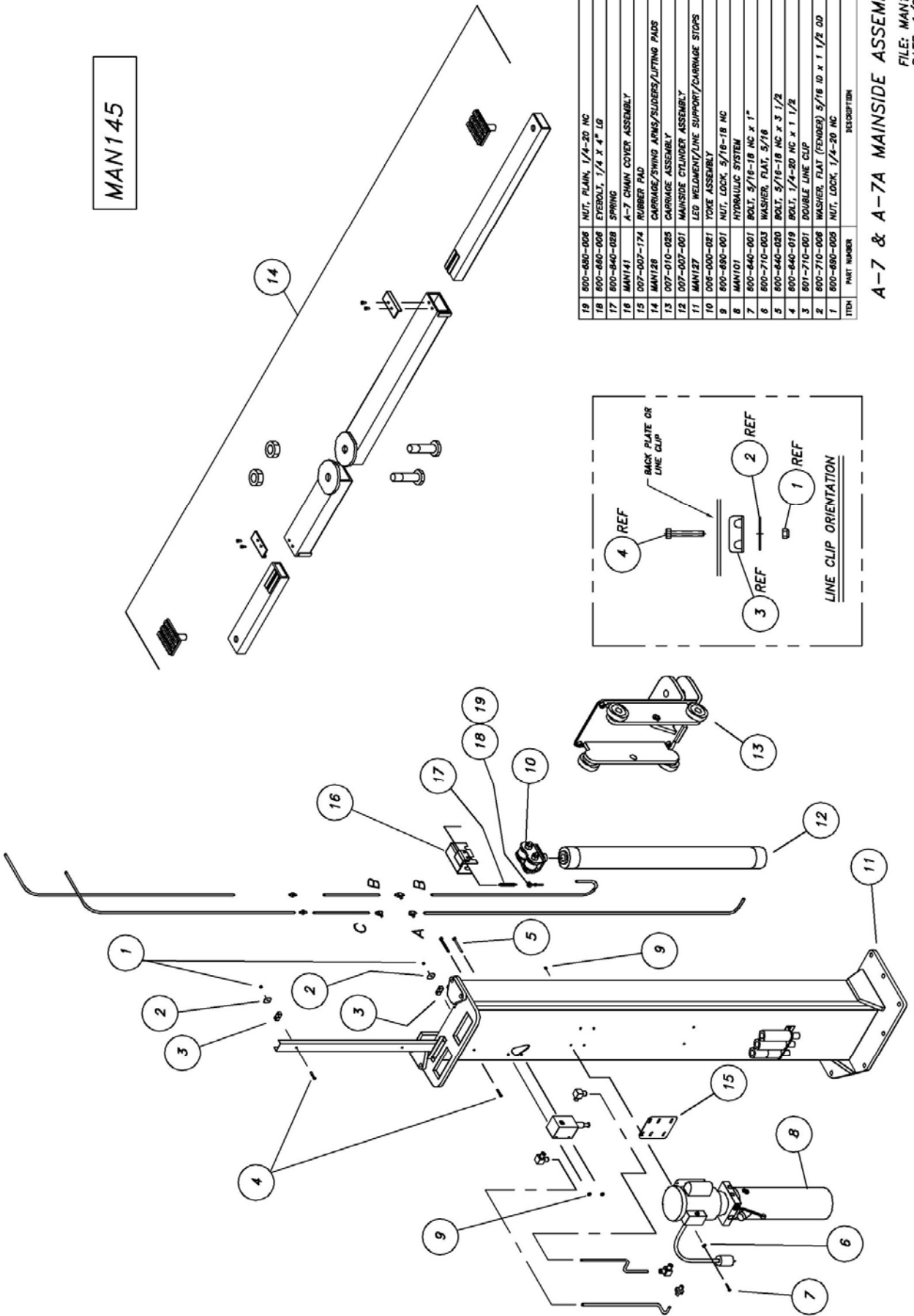

ITEM	PART NUMBER	DESCRIPTION	QTY
19	600-680-008	NUT, PLAIN, 1/4-20 NC	1
18	600-640-008	EYEBOLT, 1/4" X 4" LG	1
17	600-640-028	SPRING	1
16	MAN141	A-7 CHAIN COVER ASSEMBLY	1
15	007-007-174	RUBBER PAD	1
14	MAN128	CARRIAGE/SWING ARMS/SLIDERS/LIFTING PADS	1
13	007-010-023	CARRIAGE ASSEMBLY	1
12	007-007-001	MAINSIDE CYLINDER ASSEMBLY	1
11	MAN127	LED WELDMENT/LINE SUPPORT/CARRIAGE STOPS	1
10	000-000-021	TOKE ASSEMBLY	1
9	600-690-001	NUT, LOCK, 5/16-18 NC	6
8	MAN101	HYDRAULIC SYSTEM	1
7	600-640-001	BOLT, 5/16-18 NC X 1"	4
6	600-710-003	WASHER, FLAT, 5/16	4
5	600-640-030	BOLT, 5/16-18 NC X 3 1/2	2
4	600-640-019	BOLT, 1/4-20 NC X 1 1/2	2
3	601-710-001	DOUBLE LINE CLIP	2
2	600-710-008	WASHER, FLAT (FENDER) 5/16 ID X 1 1/2 OD	2
1	600-690-003	NUT, LOCK, 1/4-20 NC	2

A-7 & A-7A MAINSIDE ASSEMBLY  
 FILE: MAN145  
 DATE: 1/08

MAN144

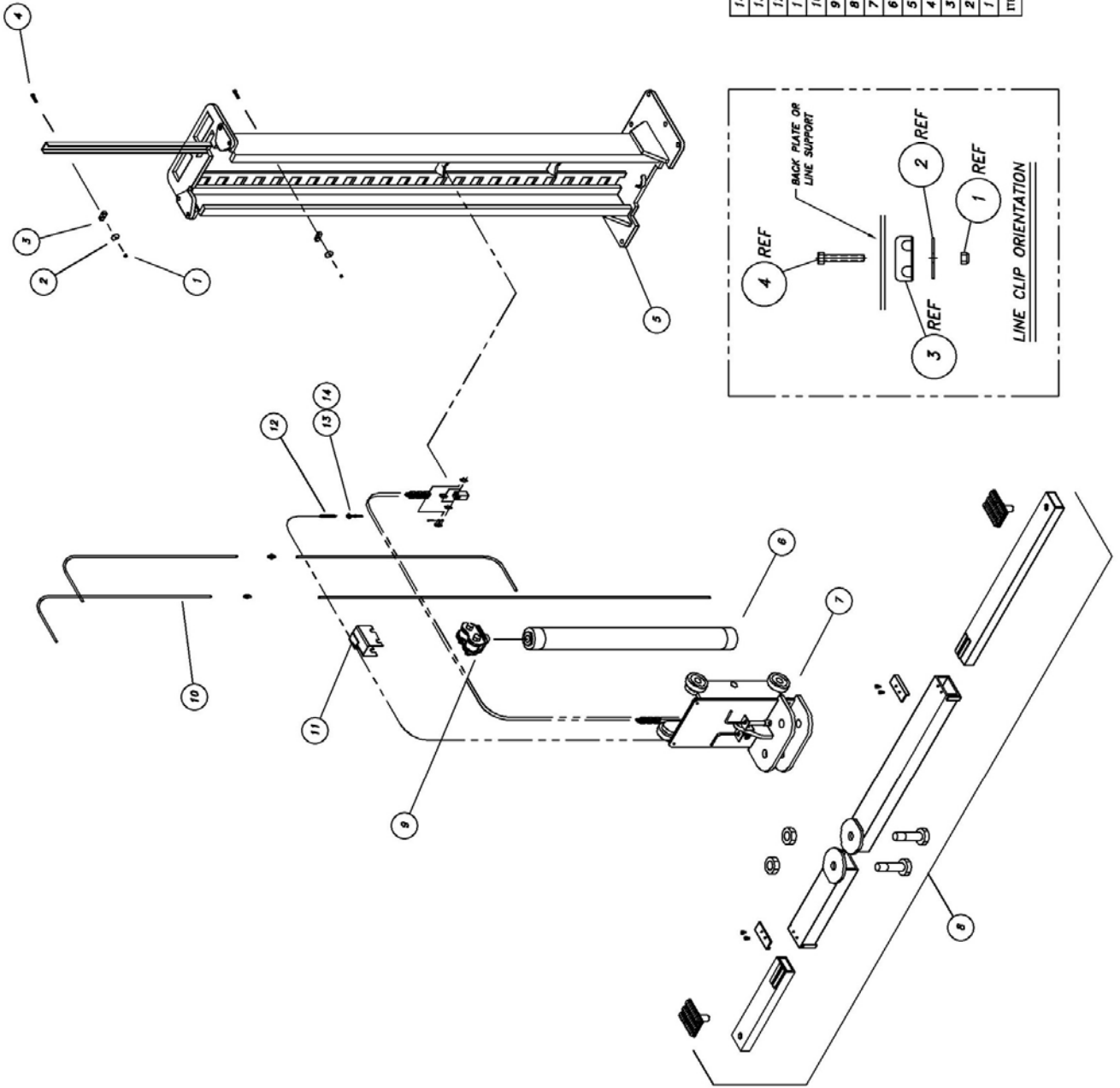

ITEM	PART NUMBER	DESCRIPTION	QTY
14	600-680-006	NUT, PLAIN, 1/4-20 NC	1
13	600-660-006	EYEBOLT, 1/4 X 4" LG	1
12	600-840-028	SPRING	1
11	MAN141	A-7 CHAIN COVER ASSEMBLY	1
10	MAN101	HYDRAULIC SYSTEM	1
9	006-000-021	YOKE ASSEMBLY	1
8	MAN126	CARRIAGE/SWING ARMS/SLIDERS/LIFTING PADS	1
7	007-010-025	CARRIAGE ASSEMBLY	1
6	007-007-002	OFFSIDE CYLINDER ASSEMBLY	1
5	MAN127	LEG WELDMENT/LINE SUPPORT/CARRIAGE STOPS	1
4	600-640-019	BOLT, 1/4-20 NC X 1 1/2	2
3	601-710-001	DOUBLE LINE CLIP	2
2	600-710-006	WASHER, FLAT (FENDER) 5/16 ID X 1 1/2 OD	2
1	600-680-005	NUT, LOCK, 1/4-20 NC	2

A-7 & A-7A OFFSIDE ASSEMBLY  
 FILE: MAN144  
 DATE: 1/08

MAN101

REV C 10/01

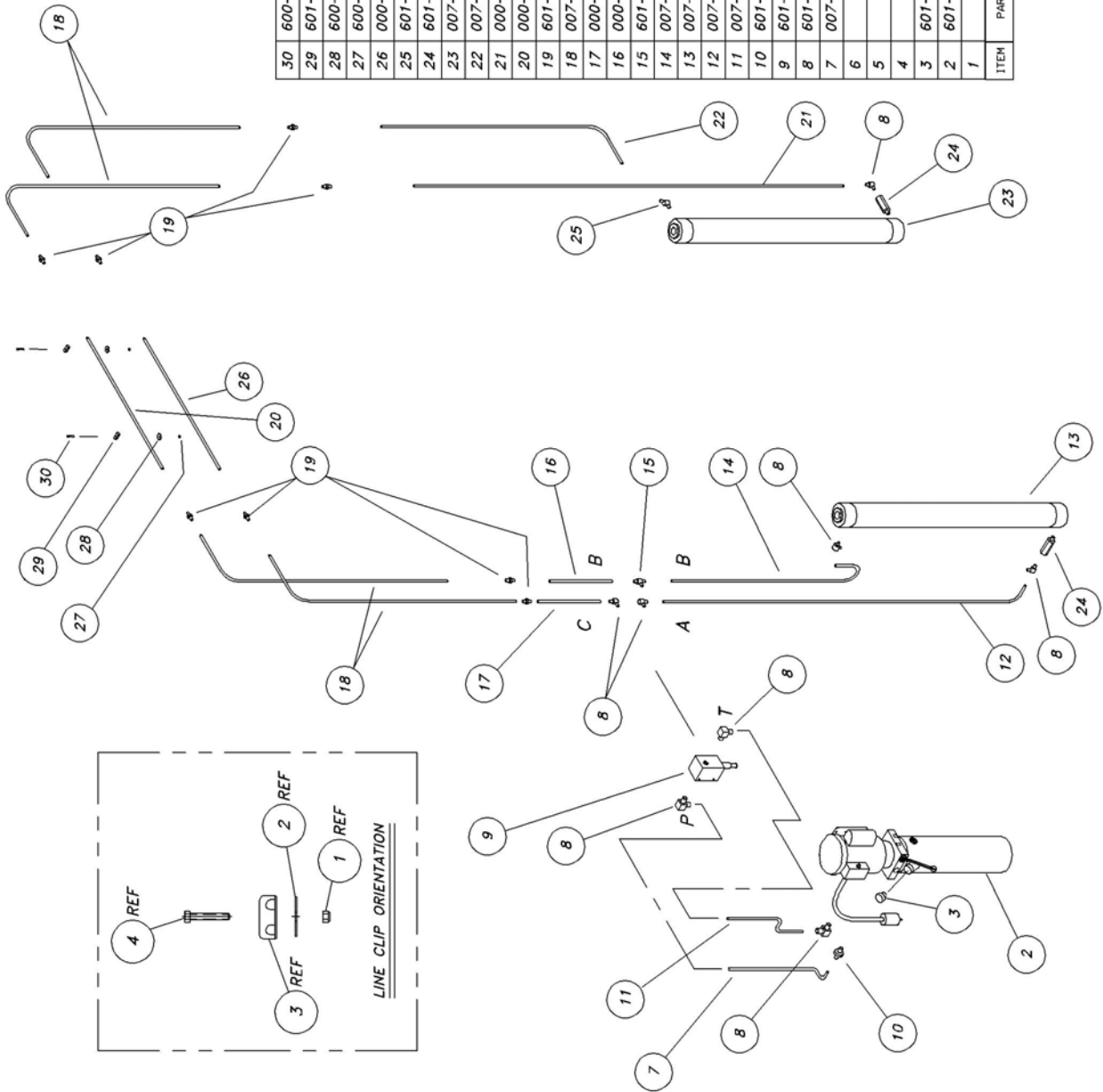

ITEM	PART NUMBER	DESCRIPTION	QTY
30	600-640-019	BOLT, 1/4-20 NC x 1 1/2, HEX HEAD CAP	2
29	601-710-001	DOUBLE LINE CLIP	2
28	600-710-006	WASHER, FLAT (FENDER) 5/16 ID x 1 1/2 OD	2
27	600-690-005	NUT, LOCK, 1/4-20 NC	2
26	000-001-013	TUBING ASSEMBLY, 85 7/8"	1
25	601-420-061	ELBOW, 45°, #6 ORB TO #6 JIC	1
24	601-410-031	VELOCITY FUSE, 4 GPM	2
23	007-007-002	CYLINDER ASSEMBLY, OFFSIDE	1
22	007-007-031	TUBING ASSEMBLY, 45 1/4"	1
21	000-001-015	TUBING ASSEMBLY, 86"	1
20	000-001-014	TUBING ASSEMBLY, 84 3/8"	1
19	601-420-011	STRAIGHT UNION, #6 JIC TO #6 JIC	8
18	007-007-020	TUBING ASSEMBLY, 64"	4
17	000-001-019	TUBING ASSEMBLY, 9 1/2"	1
16	000-001-018	TUBING ASSEMBLY, 12"	1
15	601-420-046	TEE, BRANCH, #6 ORB TO #6 JIC TO #6 JIC	1
14	007-007-050	TUBING ASSEMBLY, 43"	1
13	007-007-001	CYLINDER ASSEMBLY, MAINSIDE	1
12	007-007-051	TUBING ASSEMBLY, 74"	1
11	007-007-084	TUBING ASSEMBLY, 20 3/4"	1
10	601-420-019	STRAIGHT, #6 ORB TO #6 JIC	1
9	601-410-030	DIVERTER VALVE	1
8	601-420-017	ELBOW, 90°, #6 ORB TO #6 JIC	8
7	007-007-083	TUBING ASSEMBLY, 24 3/4"	1
6			
5			
4			
3	601-310-005	BREATHER CAP	1
2	601-300-045	POWER UNIT	1
1			

A-7 HYDRAULIC SYSTEM  
 FILE: MAN101  
 DATE: 6/95

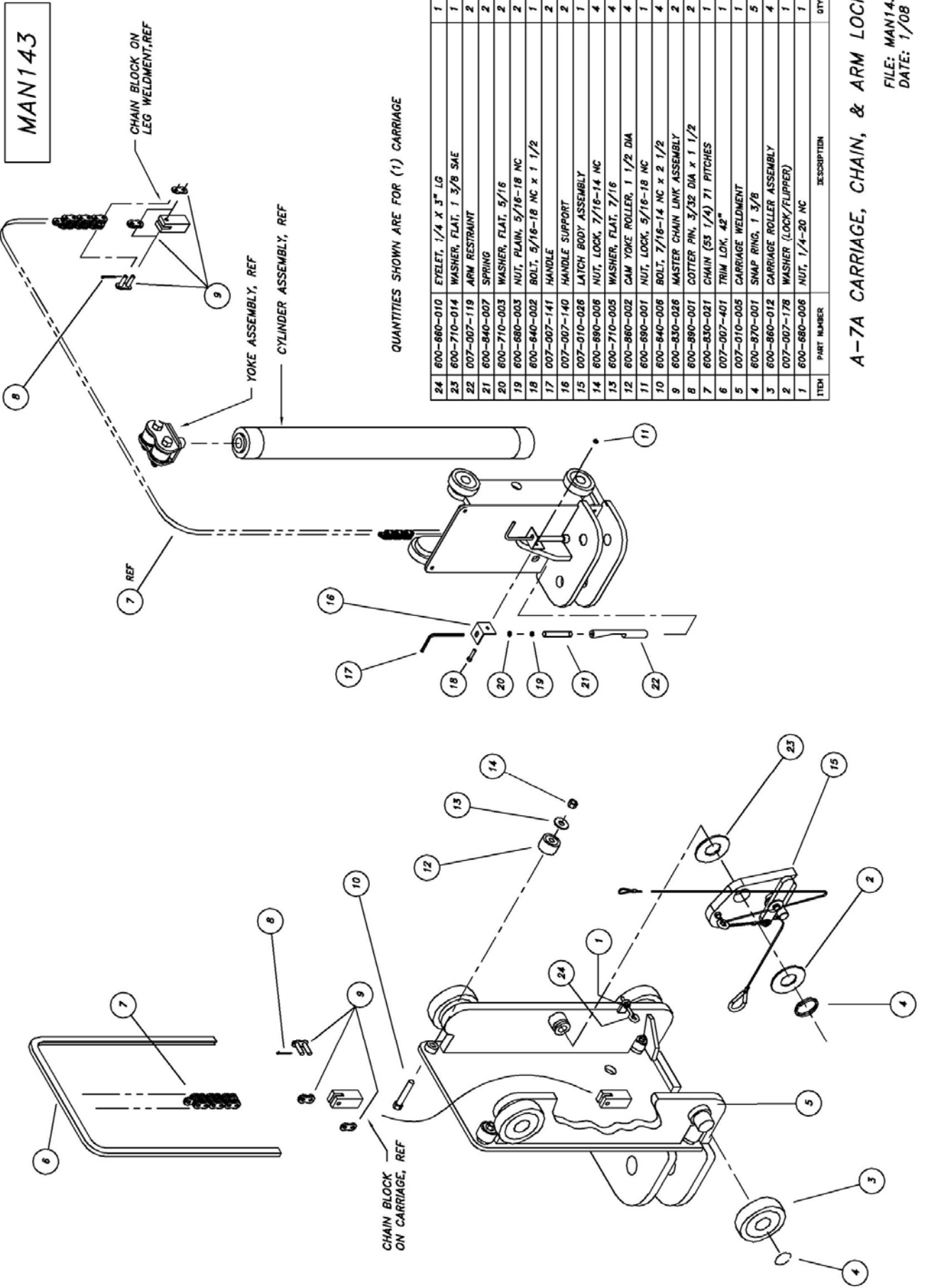

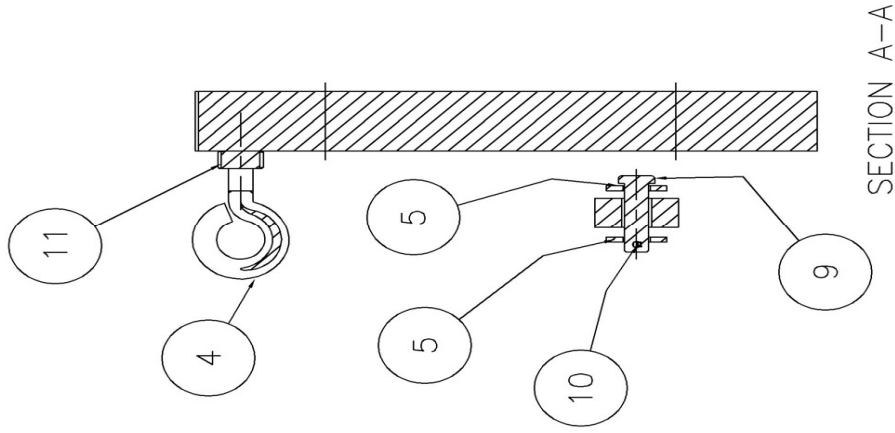

SECTION A-A

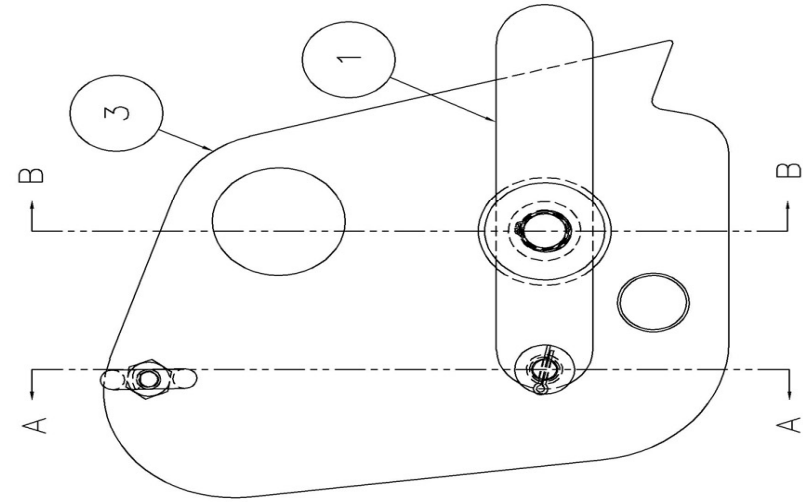

SECTION B-B

MAN142

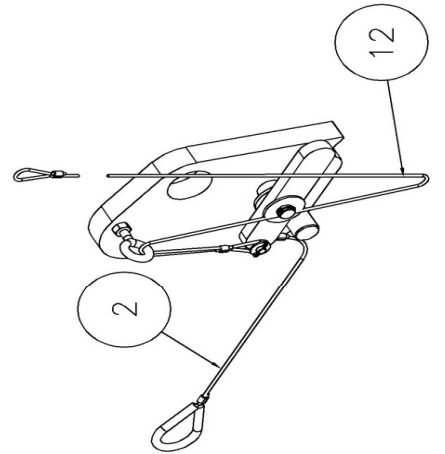

ITEM	NAME	DESCRIPTION	QTY
12	007-010-027	Chain Break Safety Cable Assy, A-7	1
11	600-680-006	Nut, Plain, 1/4-20 NC	1
10	600-890-002	Cotter Pin, 3/32 Dia x 1/2 Lg	1
9	600-880-001	Clevis Pin, 1/4 Dia x 7/8 Long	1
8	600-870-003	Snap Ring, External, 1/2	1
7	600-710-008	Washer, Flat, 1/2	1
6	600-710-005	Washer, Flat, 7/16	1
5	600-710-004	Washer, Flat, 1/4	2
4	600-660-009	Eyebolt, 2 1/2 Full Length, 1/4-20 NC	1
3	009-010-082	Lock Body Weldment, A-7 & System IA (5-2006)	1
2	007-007-046	Safety Release Cable Assy	1
1	007-007-147	Flipper	1

A-7 & A-7A LOCK BODY ASSEMBLY

FILE: MAN142  
DATE: 1/08

MAN104

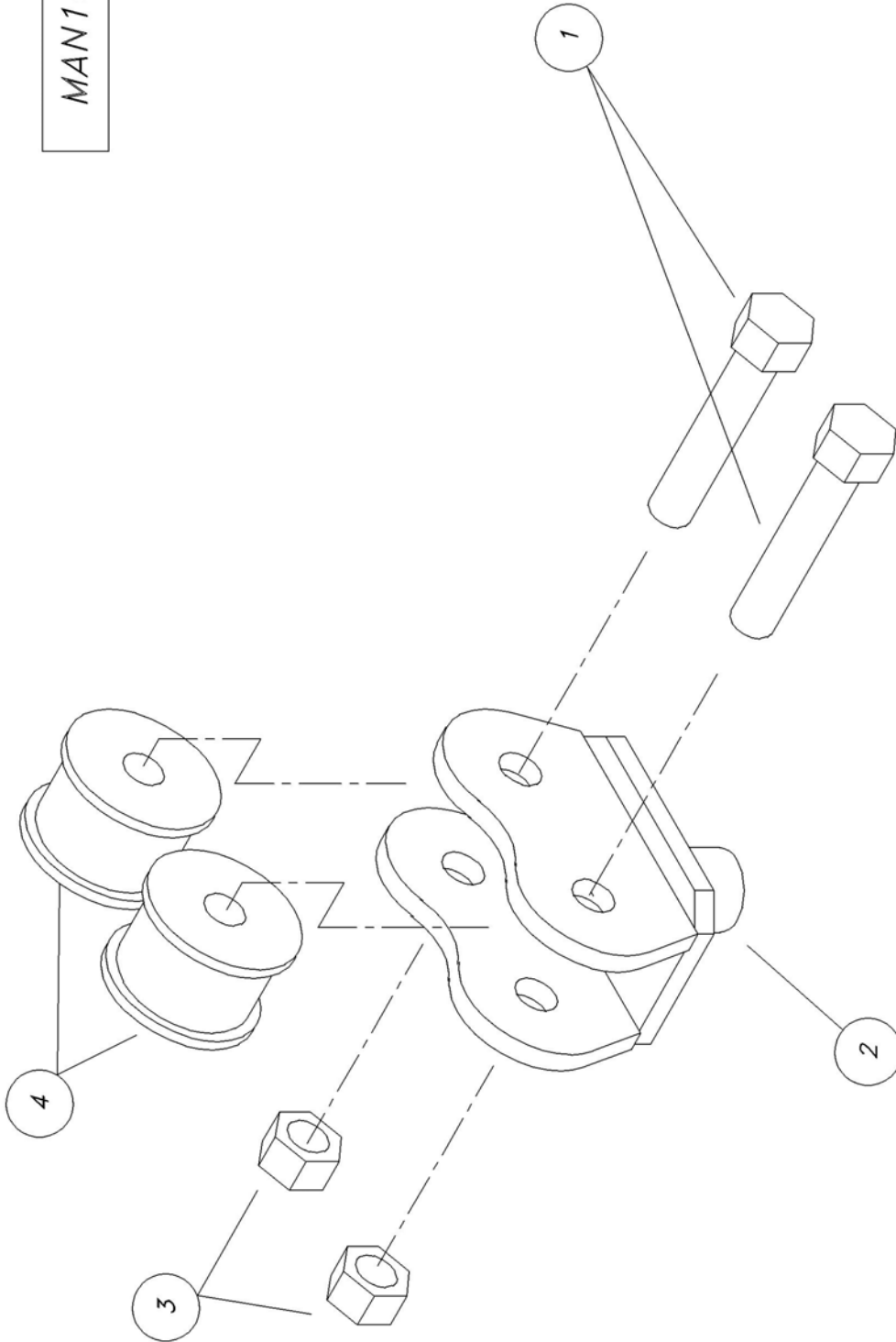

TWO (2) YOKE ASSEMBLIES PER LIFT

ITEM	PART NUMBER	DESCRIPTION	QTY
4	600-860-005	BEARING, CAM YOKE ROLLER	2
3	600-690-003	NUT, LOCK, 3/4-16 NF	2
2	006-000-012	YOKE WELDMENT	1
1	006-000-139	BOLT, 3/4-16 NF x 3 3/4 (MACHINED)	2

FILE: MAN104  
DATE: 5/96

A-7 YOKE ASSEMBLY  
(006-000-021)

MAN148

REV 1/08

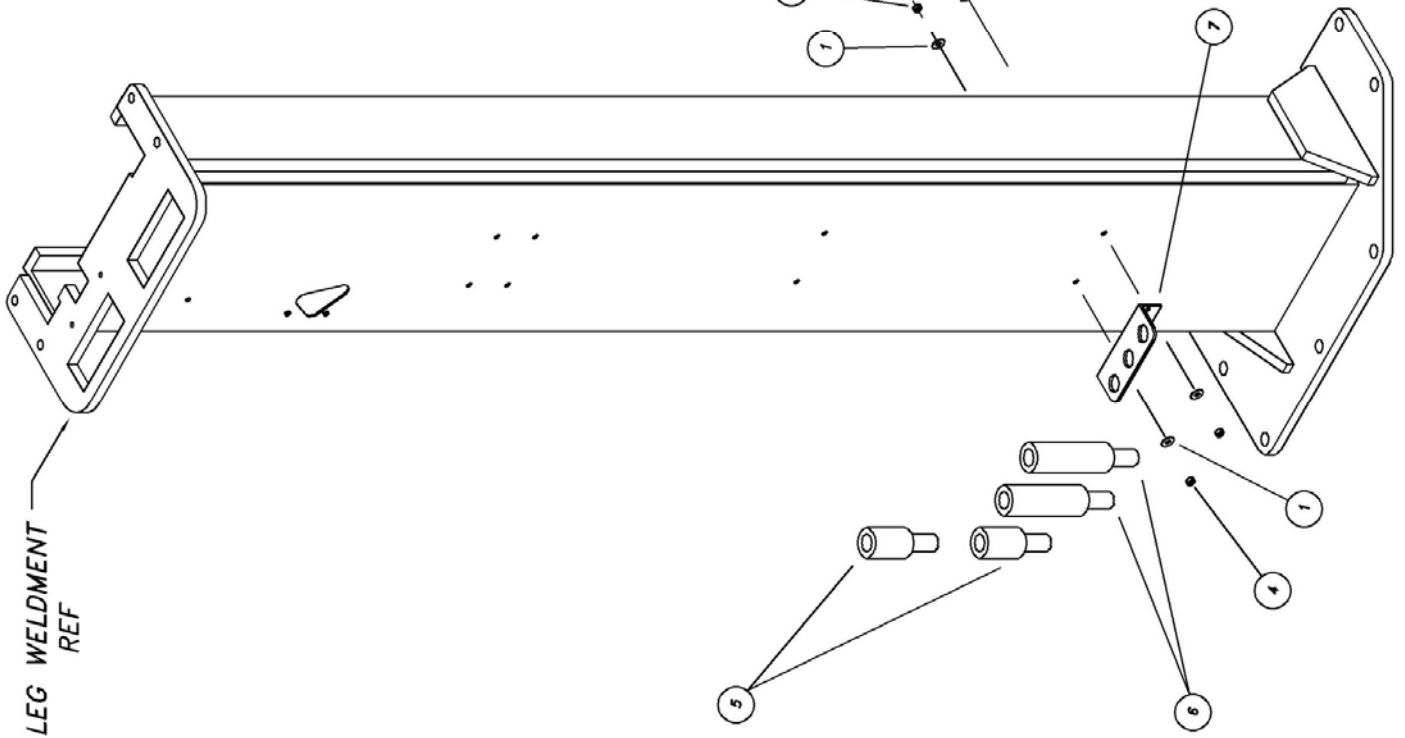

MAINSIDE LEG SHOWN  
QUANTITIES ARE THE SAME FOR THE OFFSIDE LEG

ITEM	PART NUMBER	DESCRIPTION	QTY
8	601-600-060	PLASTIC TIE, 24" LONG	1
7	025-002-126	HEIGHT ADAPTER BRACKET	1
6	025-002-128	HEIGHT ADAPTER, 6"	2
5	025-002-127	HEIGHT ADAPTER, 3"	2
4	600-680-005	NUT, LOCK, 1/4-20 NC	2
3	600-640-019	BOLT, HEX HEAD, 1/4-20 NC X 1 1/2 LG	2
2	600-680-006	NUT, PLAIN, 1/4-20 NC	2
1	600-710-004	WASHER, FLAT, 1/4	4

A-7 HEIGHT ADAPTER & BRACKET

FILE: MAN148  
DATE: 1/08

MAN147

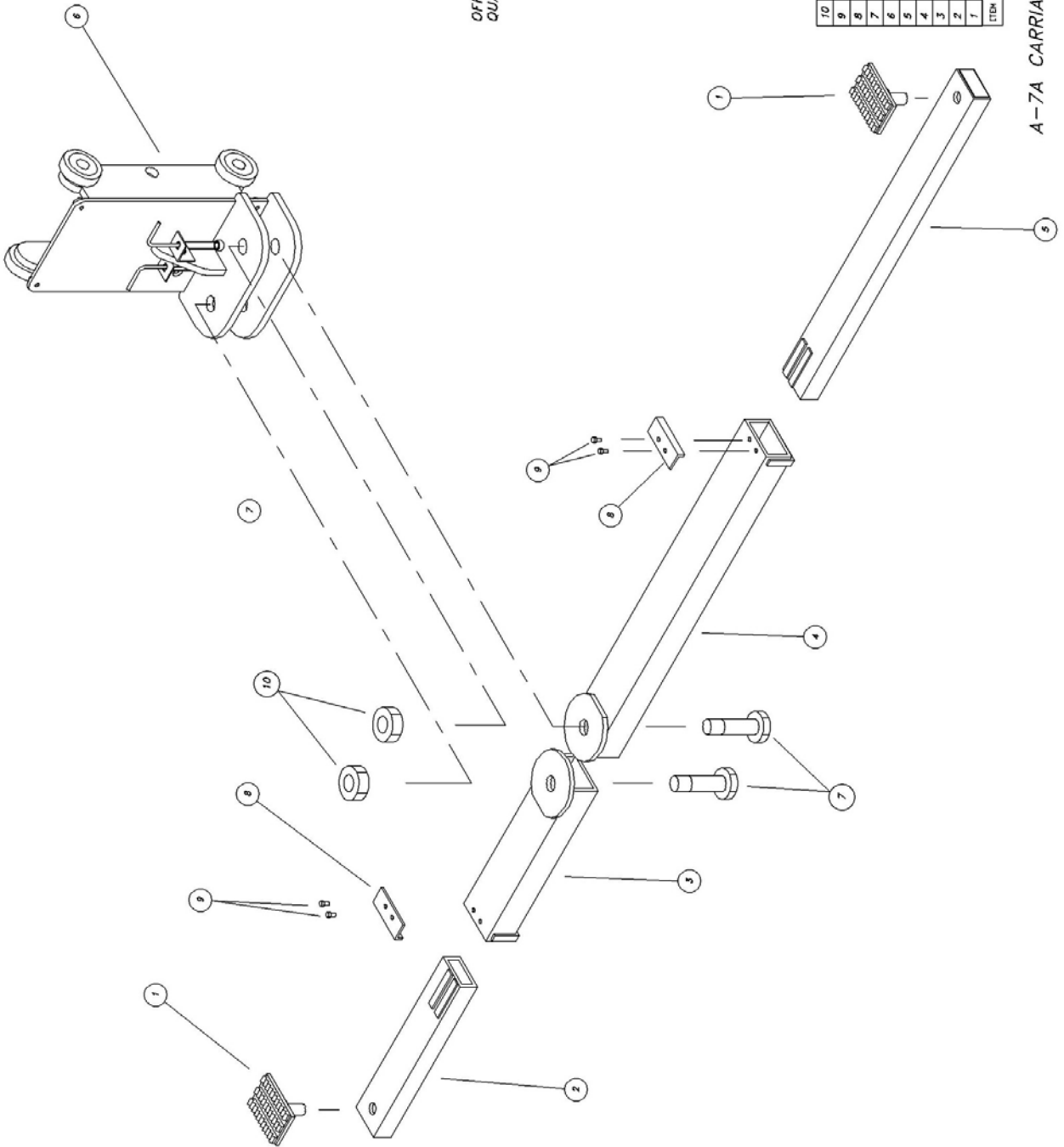

OFFSIDE CARRIAGE SHOWN  
QUANTITIES ARE THE SAME FOR THE MAINSIDE

ITEM	PART NUMBER	DESCRIPTION	QTY
10	600-690-015	NUT, LOCK (JAM), 1 1/2-12 NF	2
9	600-600-004	SCREW, SELF TAPPING, 5/16-24 NF x 5/8	4
8	007-007-130	SLIDER ARM STOP	2
7	007-010-103	SWING ARM PIN	2
6	007-010-025	CARRIAGE ASSEMBLY	REF
5	007-007-017	SLIDER (LONG)	1
4	007-007-015	SWING ARM (LONG)	1
3	007-007-076	SWING ARM (SHORT)	1
2	007-007-077	SLIDER (SHORT)	1
1	007-007-036	LIFTING PAD	2

A-7A CARRIAGE/SWING ARMS/SLIDERS/LIFTING PADS  
FILE: MAN147  
DATE: 6/06

MAN127  
REV A 2/99

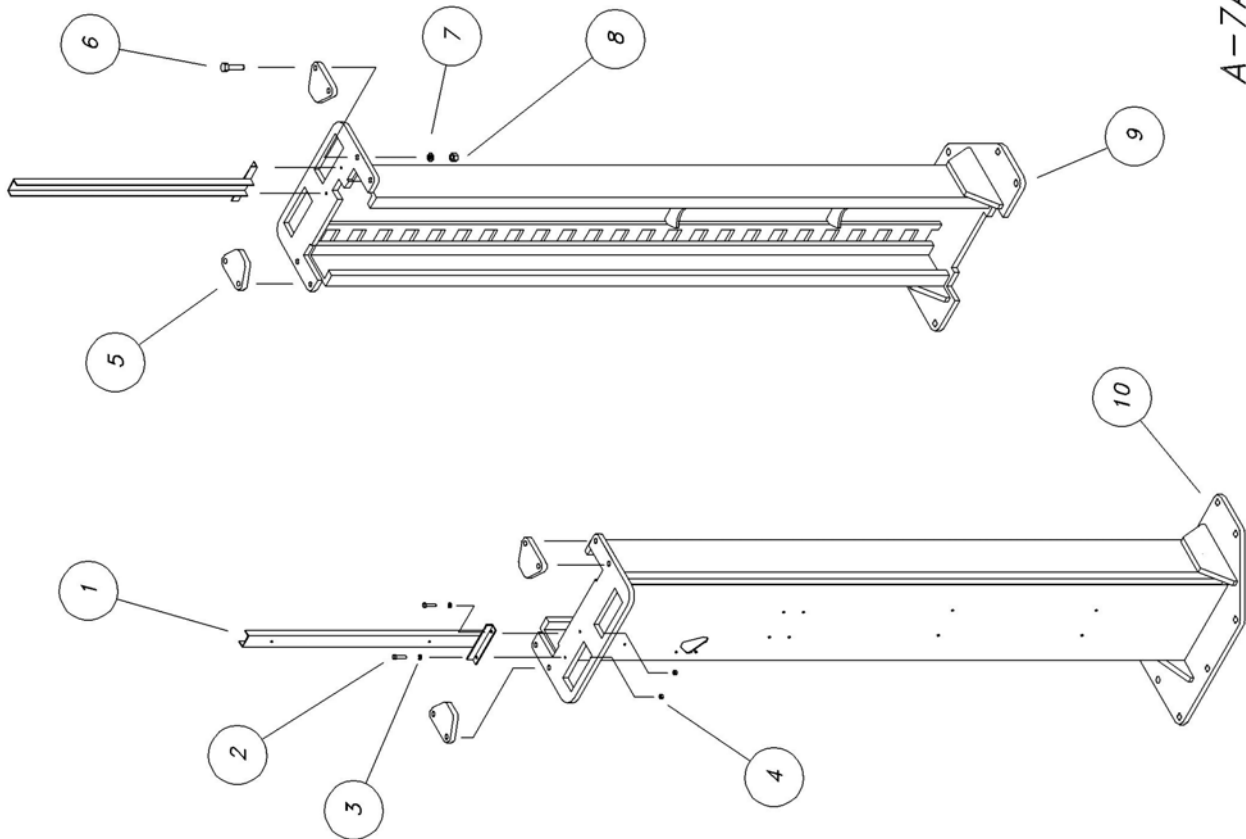

ITEM	PART NUMBER	DESCRIPTION	QTY
10	007-010-007	MAINSIDE LEG WELDMENT	1
9	007-010-008	OFFSIDE LEG WELDMENT	1
8	600-680-002	NUT, PLAIN, 5/8-11 NC	8
7	600-720-001	WASHER, LOCK, 5/8	8
6	600-640-010	BOLT, 5/8-11 NC x 2 1/2	8
5	009-001-141	CARRIAGE STOP	4
4	600-690-005	NUT, LOCK, 1/4-20 NC	4
3	600-710-004	WASHER, FLAT, 1/4	4
2	600-640-019	BOLT, 1/4-20 NC x 1 1/2	4
1	007-007-033	LINE SUPPORT	2

A-7A LEG WELDMENT/LINE SUPPORTS/CARRIAGE STOPS

FILE: MAN127  
DATE: 7/98

MAN128

REV-D 1/08

NOTES:

1. PLACE ITEM 9 IN POSITION SHOWN & MATCH DRILL (2) 3/32 DIA HOLES THRU BACK PLATE.
2. ITEMS 1 WILL BE PLACED ON SAME SIDE (MANSIDE & OFFSIDE) OF LEG AT THE ANGLED SIDE OF BASE PLATE.
3. LOCATE ITEM 9 AT 72" FROM FLOOR, CENTERED ON BACKPLATE.

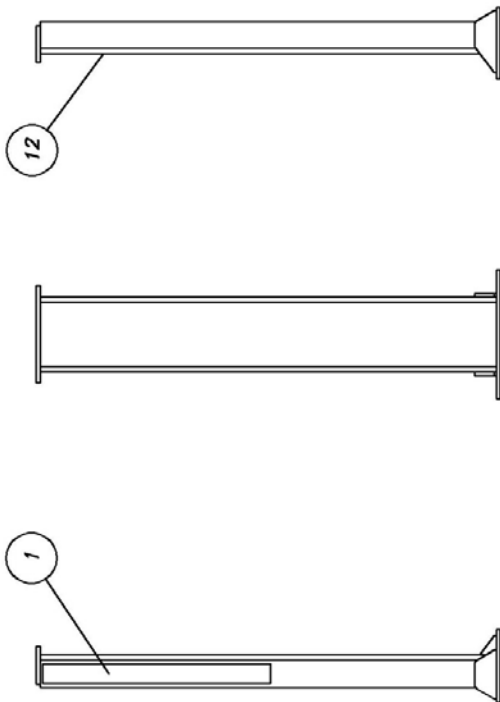

OFFSIDE VIEWS

**MOHAWK RESOURCES LTD.**  
 P.O. Box 110, Weymouth Ave., Mohawk Industrial Park  
 Weymouth, N.S. B4A 1A3, OR (902) 843-2008

MODEL # A-7A SERIAL # 7,000 lbs.

FOR USE WITH THE MOHAWK A-7A POWER UNIT. THIS EQUIPMENT IS PROTECTED BY U.S. PATENT #4500071 AND CANADIAN PATENT #4586053. THESE SERIAL NUMBERS MUST BE IDENTIFIED CORRELATIVELY WITH THE MOHAWK A-7A POWER UNIT AND THESE SERIAL NUMBERS MUST BE IDENTIFIED WITH ITS HOOP, PROTECTIONS, AND REINFORCEMENTS.

MONARCH

DYNA [ ] MODEL [ ] PACK [ ]

SERIAL [ ] G M MONARCH HYDRAULICS

16

(MOHAWK SERIAL TAG)

(MONARCH POWER UNIT DECAL)

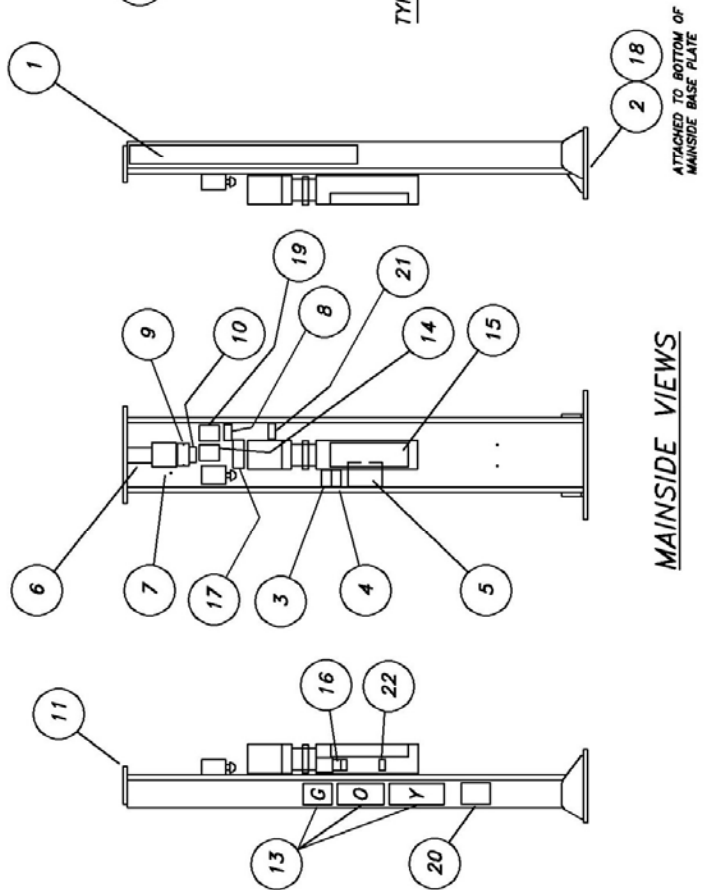

MANSIDE VIEWS

ATTACHED TO BOTTOM OF MANSIDE BASE PLATE

ITEM	PART NUMBER	DESCRIPTION	QTY
22	601-800-108	DECAL, "RISK OF EXPLOSION..."	1
21	601-800-288	DECAL, MOTOR OVERLOADS	1
20	601-800-206	DECAL, "DO NOT EXCEED MAX CAP/SW ARMS"	1
19	601-800-215	DECAL, "SAFETY INSTRUCTIONS..."	1
18	601-800-116	PACKING LIST ENVELOPE, 5 1/2 x 7 1/2	1
17	601-800-109	DECAL, WARNING, 2 1/2 x 6 1/2	3
16	---	DECAL, MONARCH, POWER UNIT	1
15	601-800-001	OPERATIONAL INSTRUCTION DECAL	1
14	601-800-310	DECAL, ETL/UL/CSA CERTIFIED, 3" x 3"	1
13	601-800-052	CAUTION, WARNING, SAFETY DECAL, 4" x 20 3/4	1
12	007-007-041	OFFSIDE LEG ASSEMBLY	REF
11	007-007-040	MANSIDE LEG ASSEMBLY	REF
10	009-010-037	"ALU" PLATE, 1 1/2 x 3 1/4	1
9	601-800-105	SERIAL, SPEC. PATENT PLATE, 2 7/16 x 4 9/16	1
8	601-800-288	LABEL "SAFETY INSTRUCTIONS"	1
7	601-800-041	MAXIMUM CAPACITY, 7000 LBS. DECAL, 5" x 5"	1
6	601-800-030	"MADE IN AMERICA" DECAL, 3 1/8 x 5 3/16	1
5	601-800-036	"WARNING", A-7 DECAL, 8" x 7"	1
4	601-800-034	"WARNING" DECAL, 2" x 3 1/2	1
3	601-800-035	"CAUTION" DECAL, 2" x 3 1/2	1
2	601-800-115	WARRANTY CARD, 4" x 5 1/2	1
1	601-800-081	"MOHAWK" DECAL, 6 3/8 x 4 1/4	2

A-7A TAG & DECAL LOCATIONS

FILE: MAN128  
DATE: 1/08

MAN109

REV. A 7/25/01

ITEM	PART NUMBER	DESCRIPTION	QTY
1	601-420-017	FITTING, 90° ELBOW	2
2	601-410-031	VELOCITY FUSE -4	1
3	601-030-008	O-RING	REF
4	007-007-110	BOTTOM GLAND	1
5	009-010-113	INLET SPOOL	1
6	601-030-002	O-RING	3
7	601-060-003	BACK-UP RING	2
8	600-840-002	SPRING	1
9	007-007-145	SET SCREW	1
10	601-030-003	O-RING	2
11	009-001-153	RETAINER	1
12	009-001-152	SPOOL	2
13	600-840-008	SPRING	1
14	009-001-151	INSERT	1
15	601-060-013	BACK-UP RING	2
16	601-010-005	PISTON T-SEAL	1
17	009-001-108	PISTON	1
18	007-007-143	WASHER	1
19	009-001-104	BARREL	1
20	025-002-132	SPIN KEY	2
21	009-001-105	ROD	1
22	601-020-003	WIPER	1
23	601-060-007	BACK-UP RING	2
24	601-000-003	ROD T-SEAL	1
25	015-000-109	ROD GLAND	1
26	601-800-021	DECAL, CAUTION	1
27	601-800-022	DECAL, PATENT	1

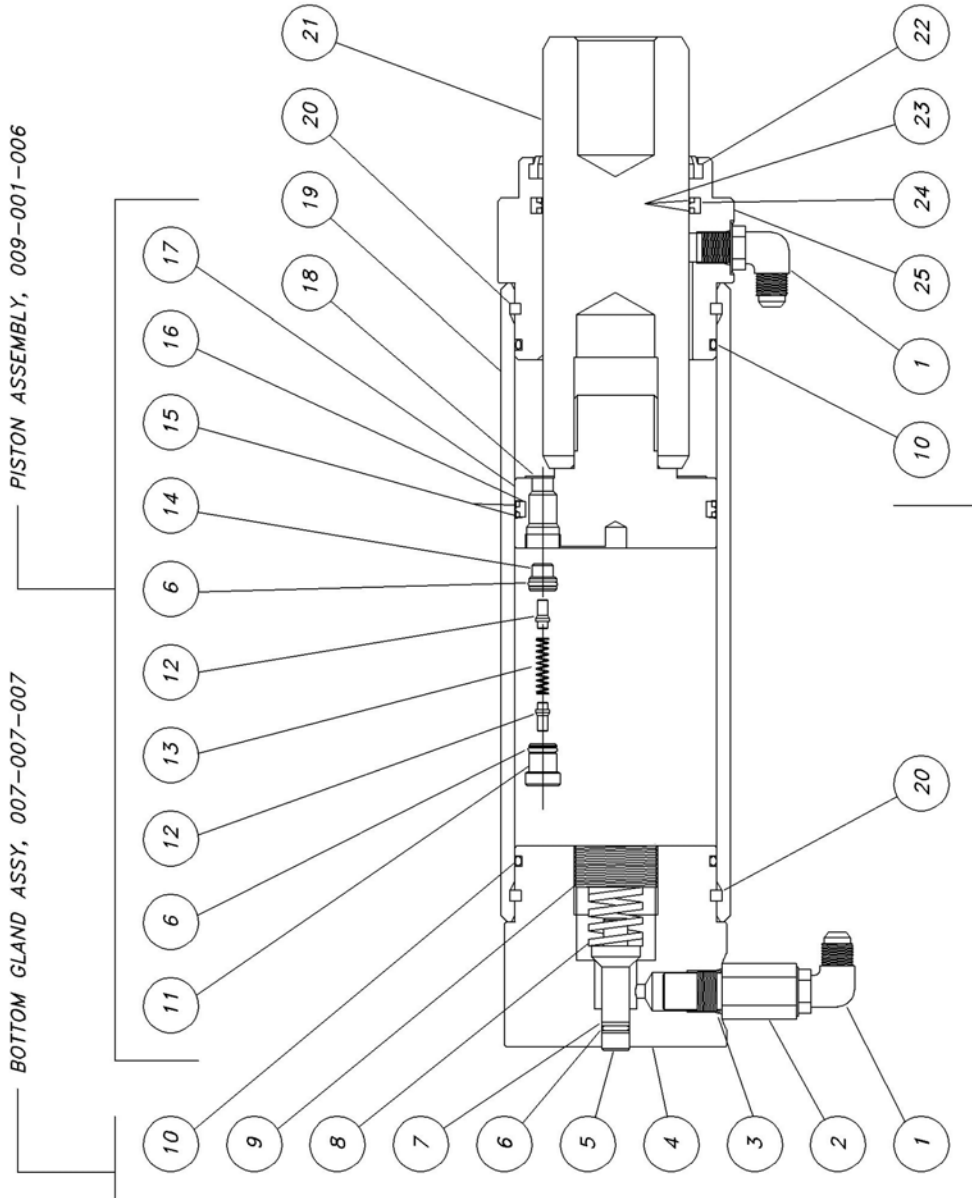

A-7  
**MAINSIDE CYLINDER ASSEMBLY**  
 (007-007-001)  
 FILE: MAN109  
 DATE 5/96

ITEM 26 APPEARS ON ITEM 4  
 ITEM 27 APPEARS ON ITEM 25

ROD GLAND HOUSING ASSEMBLY, 009-001-002

MAN110

REV-B 2/03

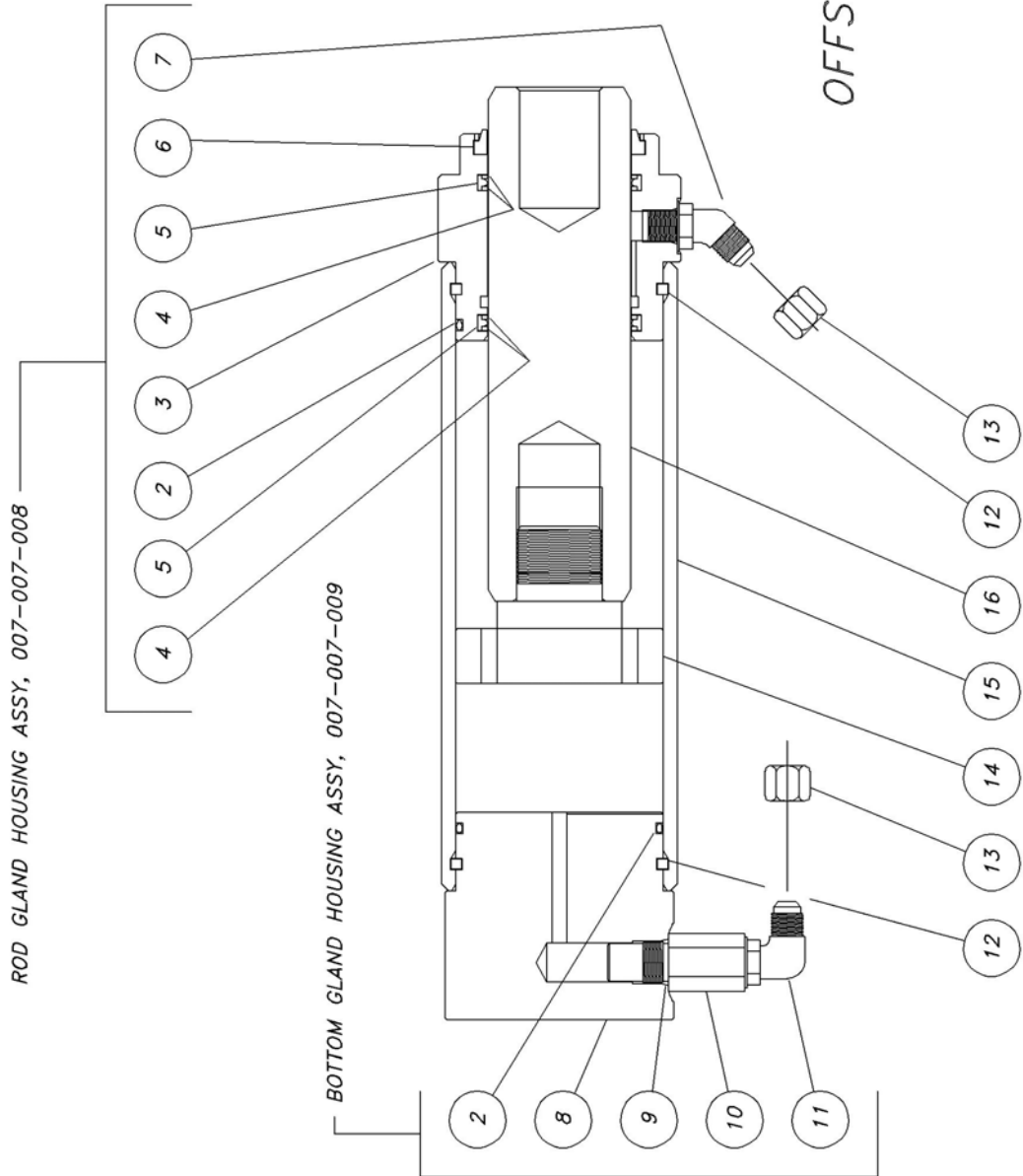

ITEM	PART NUMBER	DESCRIPTION	QTY
1			
2	601-030-003	O-RING	2
3	015-000-110	ROD GLAND	1
4	601-060-006	BACK-UP RING	4
5	601-000-002	ROD T-SEAL	2
6	601-020-002	ROD WIPER	1
7	601-420-061	FITTING, 45° ELBOW	1
8	007-007-108	BOTTOM GLAND	1
9	601-030-008	O-RING	1
10	601-410-031	VELOCITY FUSE -4	1
11	601-420-017	FITTING, 90° ELBOW	1
12	025-002-132	SPIN KEY	2
13	601-420-001	CAP NUT	2
14	007-007-101	PISTON	1
15	009-001-104	BARREL	1
16	007-007-128	ROD	1

A-7  
OFFSIDE CYLINDER ASSEMBLY  
(007-007-002)

FILE: MAN110  
DATE 5/96

**MAN131**

REV A 1/08

**BAG #2/ SHIMS (007-007-075)**

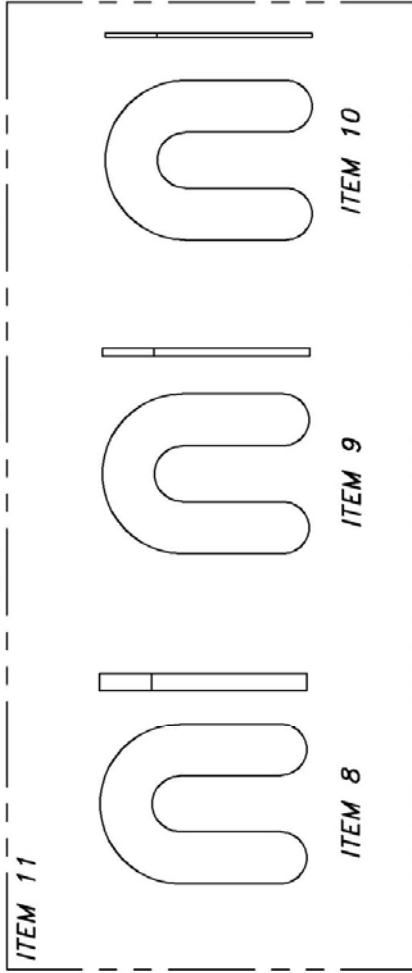

ITEMS 1 THRU 7 = BAG #1/SMALL PARTS  
 ITEMS 8 THRU 11 = BAG #2/SHIMS

**BAG #1/ SMALL PARTS (007-010-014)**

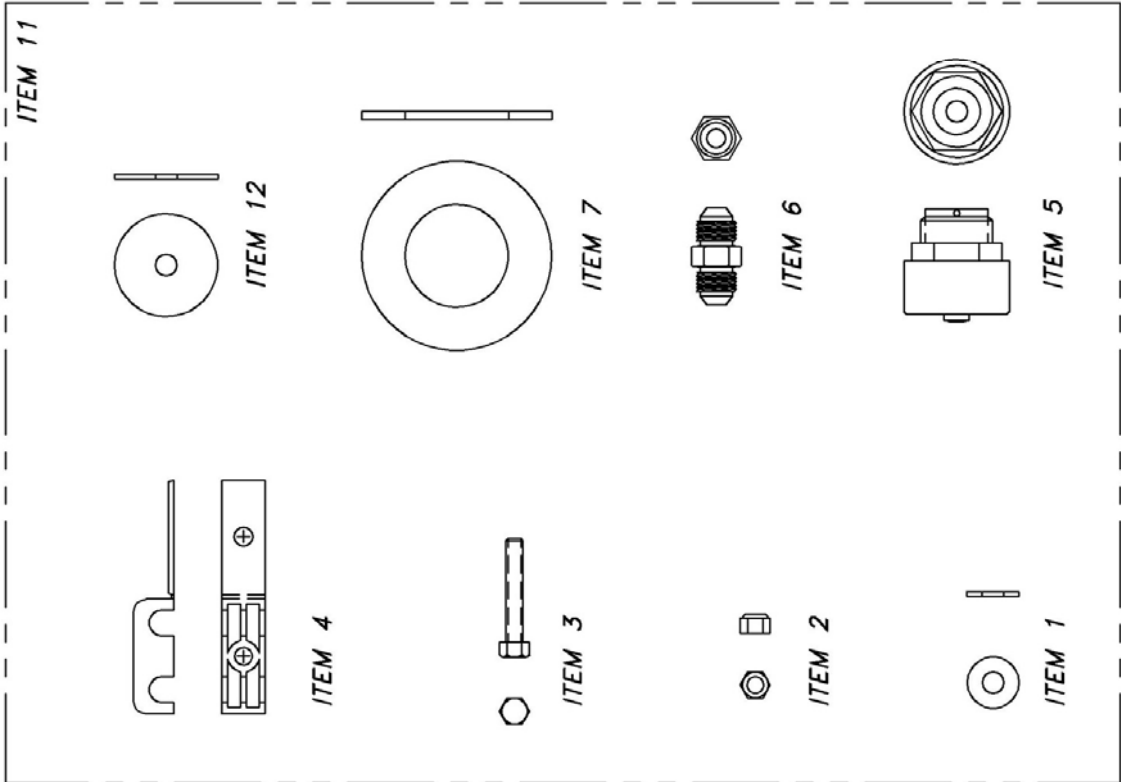

ITEM	PART NUMBER	DESCRIPTION	QTY
12	600-710-006	WASHER, FLAT (FENDER) 5/16 ID x 1 1/2 OD	4
11	601-600-022	BAG, ZIP-LOK, TRANSPARENT, 9" x 12"	2
10	600-740-001	SHIM, HORSESHOE, PLASTIC, BLUE, 1/16" THK	8
9	600-740-002	SHIM, HORSESHOE, PLASTIC, RED, 1/8" THK	8
8	600-740-003	SHIM, HORSESHOE, PLASTIC, BLACK, 1/4" THK	8
7	600-710-014	WASHER, FLAT, 1 3/8 SAE	8
6	601-420-011	UNION, #6 JIC TO #6 JIC	4
5	601-310-005	BREATHER CAP	1
4	601-710-001	DOUBLE LINE CLIP	4
3	600-640-019	BOLT, 1/4-20 NC x 1 1/2, HEX HEAD CAP	10
2	600-690-005	NUT, LOCK, 1/4-20 NC	10
1	600-710-004	WASHER, FLAT, 1/4	8

**BAG #1/SMALL PARTS & BAG #2/SHIMS**  
 FILE: MAN131  
 DATE: 1/08

ITEM 2

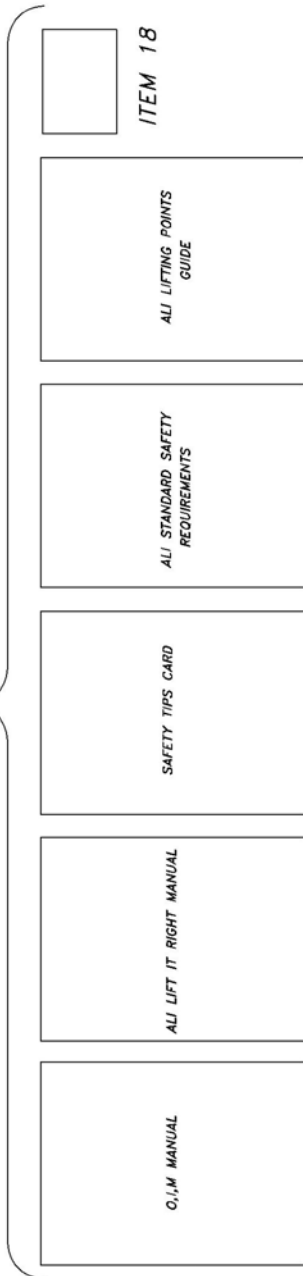

MAN132  
REV C 2/06

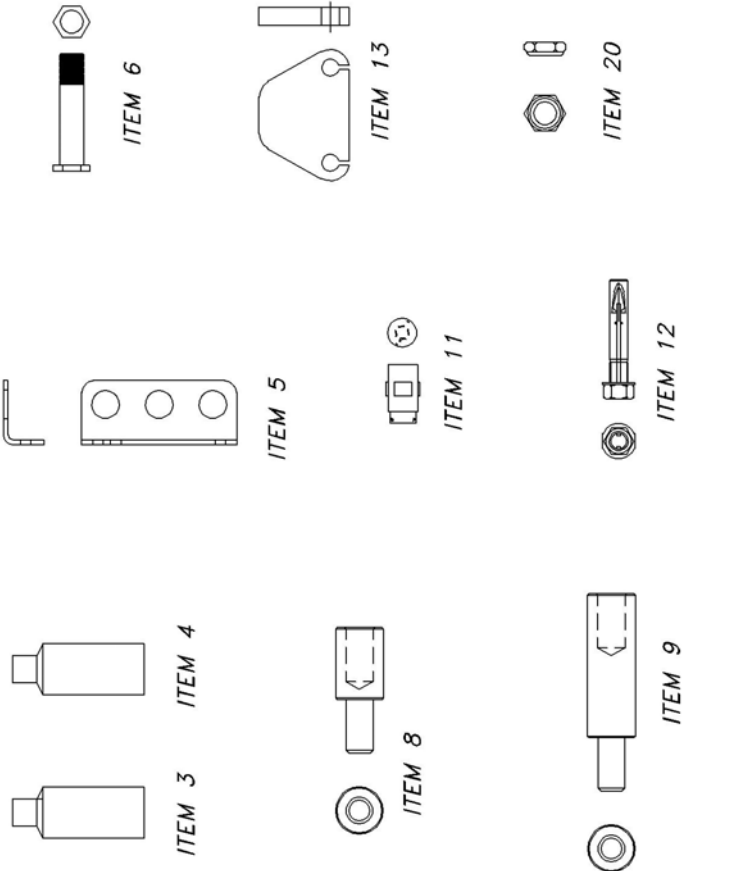

ITEM	PART NUMBER	DESCRIPTION	QTY
21	007-007-075	BAG #2/SHIMS	1
20	600-600-015	NUT, LOCK, 1 1/2-12 NF (JAM)	4
19	601-800-260	O,I,M MANUAL, A-7	1
18	601-800-115	WARRANTY CARD, 4" x 5 1/2	1
17	601-800-092	ALI LIFTING POINTS GUIDE	1
16	601-800-007	ALI STANDARD SAFETY REQUIREMENTS	1
15	601-800-008	SAFETY TIPS CARD	1
14	601-800-003	SAFETY MANUAL, ALI, LIFT IT RIGHT	1
13	009-001-141	CARRIAGE STOP	4
12	600-670-002	WEJ-IT, 3/4 X 5"	14
11	601-170-008	CONNECTOR, 4 PRONG, NEMA #L14-20R	1
10	007-010-014	BAG #1/SMALL PARTS	1
9	025-002-128	HEIGHT ADAPTER, 6"	4
8	025-002-127	HEIGHT ADAPTER, 3"	4
7	007-007-036	LIFTING PAD WELDMENT	4
6	007-010-103	SWING ARM PIN, 1/2 DIA x 6 3/4	4
5	025-002-126	HEIGHT ADAPTER BRACKET	2
4	601-630-001	PAINT, SPRAY, RED	1
3	601-630-002	PAINT, SPRAY, YELLOW	1
2	007-010-016	MANUAL ASSEMBLY, A-7	1
1	601-600-020	BOX, CORRUGATED	1

BREAKDOWN OF ITEM 2

A-7A PARTS BOX & CONTENTS  
FILE: MAN132  
DATE: 7/98

MAN235

REV B 2/06

BACK VIEW:

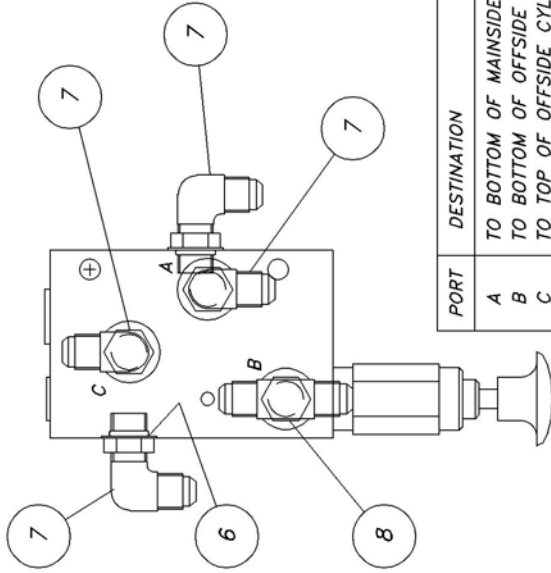

PORT	DESTINATION
A	TO BOTTOM OF MAINSIDE CYLINDER
B	TO BOTTOM OF OFFSIDE CYLINDER
C	TO TOP OF OFFSIDE CYLINDER
P	TO PUMP PRESSURE PORT
T	TO TANK (RESERVOIR)

RIGHT SIDE VIEW:

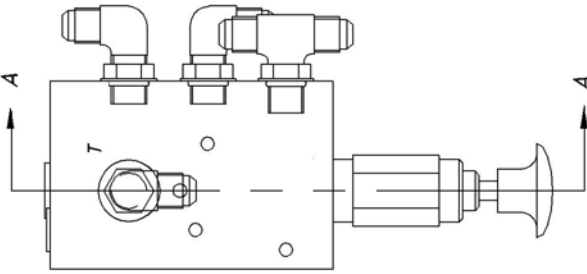

FRONT VIEW:  
(SECTION A-A)

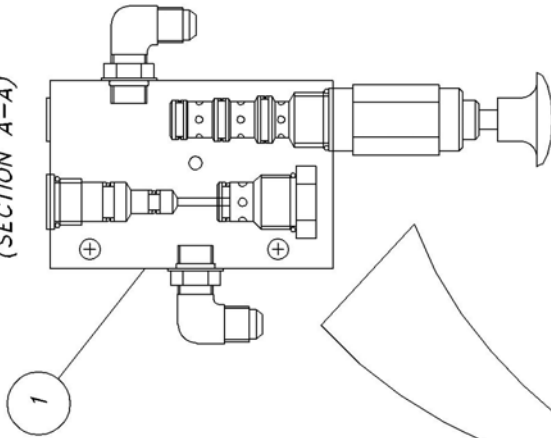

LEFT SIDE VIEW:

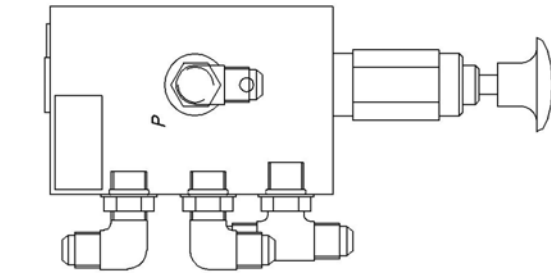

TOP VIEW:

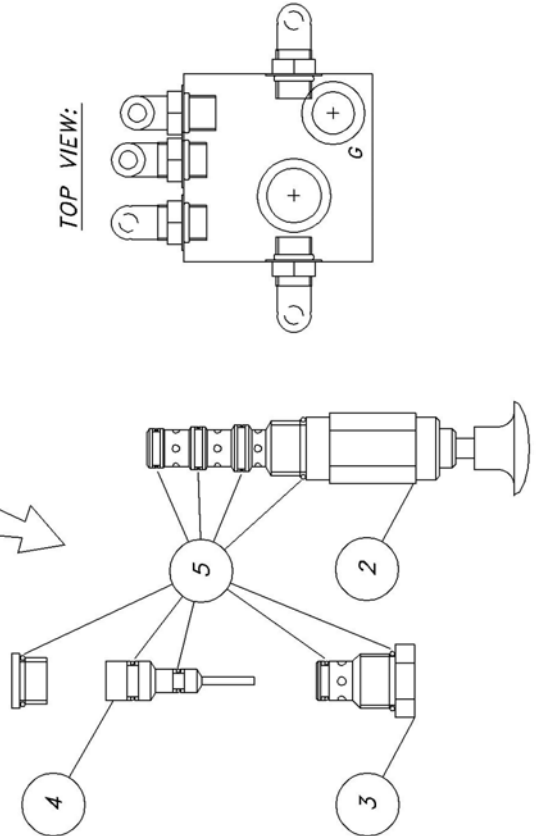

ITEM	PART NUMBER	DESCRIPTION	QTY
8	601-420-046	FITTING, TEE BRANCH, #6 JIC/ #6 ORB	1
7	601-420-017	FITTING, ELBOW, 90°, #6 ORB TO #6 JIC	4
6	601-030-017	O-RING	5
5	212239ASK	SEAL REPAIR KIT	1
4	282247AA	PILOT PISTON ASSY	1
3	CV10-20-0-N-05	CHECK VALVE	1
2	MP10-42K-0-N	MANUAL PULL VALVE	1
1	601-410-030	DIVERTER VALVE	1

FILE: MAN235  
DATE 4/96

DIVERTER VALVE ASSEMBLY

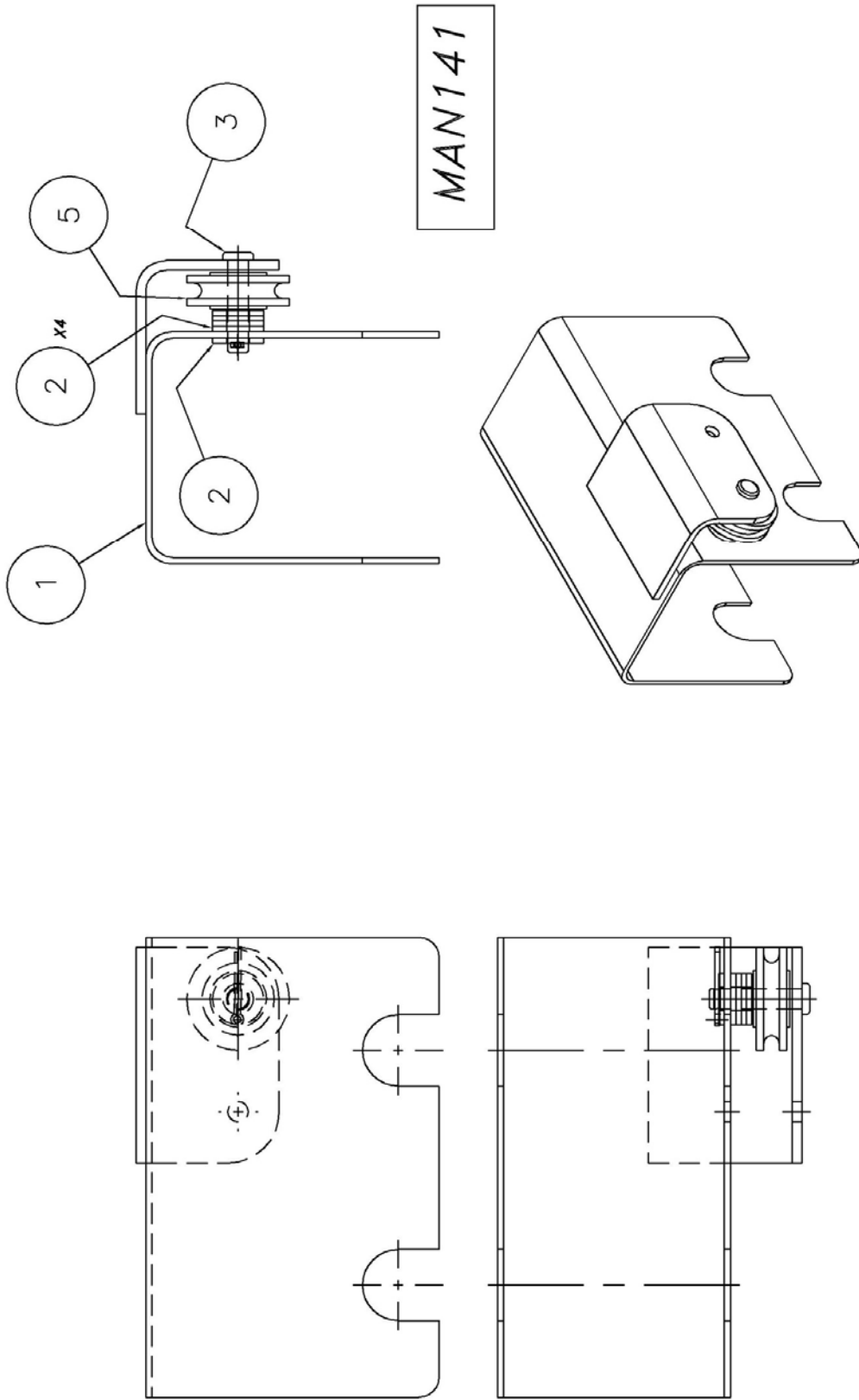

ITEM	NAME	DESCRIPTION	QTY
5	600-920-019	Sheave, 1.25 OD x .25 ID	1
4	600-890-003	Cotter Pin, 1/16 x 3/4	1
3	600-880-007	Clevis Pin, 1/4 Dia x 1 1/8 Long	1
2	600-710-004	Washer, Flat, 1/4	5
1	007-010-023	Chain Cover Weldment	1

Parts List  
**A-7 CHAIN COVER ASSEMBLY**

FILE: MAN141 DATE: 1/08

# **MOHAWK**

**PRE-EXISTING  
SLAB REQUIREMENTS  
&  
NEW SLAB RECOMMEDATIONS**



## **MOHAWK RESOURCES LTD.**

65 VROOMAN AVE.

AMSTERDAM, NY 12010

**TOLL FREE : 1-800-833-2006**

**LOCAL : 1-518-842-1431**

**FAX : 1-518-842-1289**

**INTERNET: [www.MOHAWKLIFTS.com](http://www.MOHAWKLIFTS.com)**

**E-MAIN: [Service@MOHAWKLIFTS.com](mailto:Service@MOHAWKLIFTS.com)**

# Mohawk Resources Ltd.



## PRE-EXISTING Minimum Floor Requirements

Mohawk Lift Model	Minimum Slab Thickness	Minimum Compressive Strength	Reinforcement Size	Reinforcement Spacing (Rebar)
A-7	4-1/2"	4000 psi with 28 day aging	#6 rebar	12 in.
System IA	4-1/2"	4000 psi with 28 day aging	#6 rebar	12 in.
System IA-10	4-1/2"	4000 psi with 28 day aging	#6 rebar	12 in.
LMF-12	6 1/2"	4000 psi with 28 day aging	#6 rebar	12 in.
TP-15	6 1/2"	4000 psi with 28 day aging	#6 rebar	10 in.
TP-16	6 1/2"	4000 psi with 28 day aging	#6 rebar	10 in.
TP-18	8"	4000 psi with 28 day aging	#6 rebar	10 in.
TP-20	8"	4000 psi with 28 day aging	#6 rebar	10 in.
TP-26	12"	4000 psi with 28 day aging	#6 rebar	10 in.
TP-26-W	8"	4000 psi with 28 day aging	#6 rebar	10 in.
TP-30	12"	4000 psi with 28 day aging	#6 rebar	10 in.
TP-30-W	8"	4000 psi with 28 day aging	#6 rebar	10 in.
TR-19	4 1/2"	n/a	ACI Temp only*	ACI Temp only*
FL-25	4 1/2"	n/a	ACI Temp only*	ACI Temp only*
TR-25A	4 1/2"	n/a	ACI Temp only*	ACI Temp only*
TR-33	6" or (4 1/2" **)	n/a	ACI Temp only*	ACI Temp only*
TR-35	6" or (4 1/2" **)	n/a	ACI Temp only*	ACI Temp only*
TR-50	6" or (4 1/2" **)	n/a	ACI Temp only*	ACI Temp only*
TR-75	6" or (4 1/2" **)	n/a	ACI Temp only*	ACI Temp only*

\* The floor must be properly aged to American Concrete Institute specifications. The floor does not require reinforcement, but a minimum of wire mesh is recommended.

\*\* Larger 4' x 4' base pads (available from Mohawk) required for floors with a thickness range less than 6", but greater or equal to 4 1/2".

The floor should be test drilled to verify minimum floor thickness and to confirm building drawings. A core sample should be obtained and tested to verify minimum floor compressive strength. When investigating floor properties, consult building drawings to verify proper floor reinforcement.

All 2-post lifts require a continuous single slab. Spanning expansion seams or positioning posts on separate slabs is not acceptable.

### --- ALL MOHAWK LIFTS MUST BE INSTALLED ON CONCRETE ONLY ---

**DO NOT** install any Mohawk lift on any surface other than concrete, conforming to the minimum compressive strength, aging, reinforcement, and thickness stated in the table above.

**DO NOT** install any Mohawk lift on expansion seams or on cracked or defective concrete. All 3/4 inch diameter anchors must be a minimum of 6 inches away from any expansion seams, control joints or other inconsistencies in the concrete. All 1 inch diameter anchors must be a minimum of 7 1/2 inches away from any expansion seams, control joints or other inconsistencies in the concrete. Refer to anchor manufacturer specifications for specific information concerning edge distances and bolt to bolt distance requirements.

**NEVER, NEVER** install a Mohawk lift on hand mixed concrete.

**DO NOT** install any Mohawk lift on a secondary floor level or on any ground floor with a basement beneath without written authorization from the building architect and prior consultation and approval from Mohawk Resources Ltd.

If the floor does not meet these minimum pre-existing floor requirements, it is suggested to construct a slab as outlined in *New Slab Recommendations*. If the location of the lift is in a seismic zone, contact Mohawk Resources Ltd. for seismic slab designs.

## New Slab Recommendations:

The information contained in this appendage supercedes any other information given in the accompanied manual. This information is presented for design recommendations for a new concrete slab in the event that the pre-existing floor does not meet minimum requirements of the applicable lift type. Please read all instructions below carefully before producing new slab.

### Basic Concrete Requirements:

Minimum Tensile Strength of Concrete:	4,000 P.S.I.
Minimum Aging of New Concrete Slab:	28 days (cure time)
Minimum Thickness of Concrete Slab:	See New Slab Table & Figure Attached
Minimum Width and Length of Slab:	See New Slab Table & Figure Attached

All properties of the new concrete slab are mandatory and must conform to the above stated properties before installation of the lift is deemed acceptable. The new slab must be totally surrounded by an existing concrete floor. Certified strength documentation should be obtained from the firm who supplies the concrete mixture at the time of the pour.

The slab above is designed as “stand alone” and does not take into account the contribution of strength from surrounding concrete. It may be desirable to reinforce the new slab to the pre-existing surrounding floor. Care should be taken to locate these specific reinforcement bars away from any anchor positions of the specific lift.

This new slab design does not account for second floor installations or installations in a ground floor with a basement beneath. For this case, the lift should not be installed without written authorization from the building architect.

All ¾ inch diameter anchors must be a minimum of 6 inches away from any expansion seams, control joints or other inconsistencies in the concrete. All 1 inch diameter anchors must be a minimum of 7 ½ inches away from any expansion seams, control joints or other inconsistencies in the concrete. Refer to anchor manufacturer specifications for specific information concerning edge distances and bolt to bolt distance requirements.

NEVER, NEVER, hand mix your own concrete.

Rev: 6/7/06  
File: New-Slab.doc

## New Slab Recommendations

File: New-slab.xls

Rev Date: 6/7/06

**NEW SLABS MUST BE 12" THICK MINIMUM !! (See Notes Below)**

Lift Model	W Slab Width, (Inches)	L Slab Length, (Inches)	R Reinforcement Size, (Inch) (See Note 1 & 2)	S1 & S2 Reinforcement Spacing, (Inch) (See Note 3)	D Wej-it Dia, (Inch)	I Wej-it Length, (Inch)
A-7	48" Min	144" Min	8 - #4 - Main Bars 21 - #4 - Temperature Bars	6 in - Long Bars 8 in - Short Bars	3/4 in	5 in
System IA	48" Min	161" Min	8 - #4 - Main Bars 21 - #4 - Temperature Bars	6 in - Long Bars 8 in - Short Bars	3/4 in	5 in
System IA-10	48" Min	161" Min	8 - #4 - Main Bars 21 - #4 - Temperature Bars	6 in - Long Bars 8 in - Short Bars	3/4 in	5 in
LMF-12	72" Min	168" Min	12 - #4 - Main Bars 23 - #4 - Temperature Bars	6 in - Long Bars 8 in - Short Bars	3/4 in	6 in
TP-15	72" Min	168" Min	12 - #4 - Main Bars 23 - #4 - Temperature Bars	6 in - Long Bars 8 in - Short Bars	3/4 in	6 in
TP-16	72" Min	168" Min	12 - #4 - Main Bars 23 - #4 - Temperature Bars	6 in - Long Bars 8 in - Short Bars	3/4 in	6 in
TP-18	72" Min	186" Min	18 - #4 - Main Bars 24 - #4 - Temperature Bars	4 in - Long Bars 8 in - Short Bars	3/4 in	6 in
TP-20	72" Min	186" Min	18 - #4 - Main Bars 24 - #4 - Temperature Bars	4 in - Long Bars 8 in - Short Bars	3/4 in	6 in
TP-26	72" Min	198" Min	18 - #4 - Main Bars 24 - #4 - Temperature Bars	4 in - Long Bars 8 in - Short Bars	1 in	10 in
TP-30	72" Min	198" Min	18 - #4 - Main Bars 24 - #4 - Temperature Bars	4 in - Long Bars 8 in - Short Bars	1 in	10 in
TR-19 *	24" Min	24" Min	4 - #4 Bars 8 Bars Total	6 in - Each Way	3/4 in	5 in
FL-25 *	24" Min	24" Min	4 - #4 Bars 8 Bars Total	6 in - Each Way	3/4 in	5 in
TR-25 *	24" Min	24" Min	4 - #4 Bars 8 Bars Total	6 in - Each Way	3/4 in	5 in
TR-33 *	72" Min	72" Min	12 - #4 Bars 24 Bars Total	6 in - Each Way	3/4 in	5 in
TR-35 *	72" Min	72" Min	12 - #4 Bars 24 Bars Total	6 in - Each Way	3/4 in	5 in
TR-50 *	72" Min	72" Min	12 - #4 Bars 24 Bars Total	6 in - Each Way	3/4 in	5 in
TR-75 *	72" Min	72" Min	12 - #4 Bars 24 Bars Total	6 in - Each Way	3/4 in	5 in

\* Four Separate Slabs Formed at each Post.

Note 1: An additional layer of 6 x 6 - 10/10 WWF at mid height of new slab would be advisable in any extremely hot or cold climate to control cracking due to temperature fluctuations and shrinkage.  
At anchor bolt locations only keep WWF mesh below the elevation of the anchorage to avoid drilling interference with the wire.

Note 2: The main reinforcing and lower temperature steel shall be Grade 60 deformed bars

Note 3: The tolerance on spacing of the bars in each direction shall be the value shown, plus or minus 1 inch.  
In addition, the number of bars specified in the table must be used.

Note 4: The concrete outline dimensions and the reinforcing shown are for a foundation bed allowable bearing capacity of not less than 2,000 lb/sq ft (1 ton per square foot). Many clays, and most all firm clay, hard clay, sand & clay mixes, dry sands, coarse dry sands, dry sand and silt mixes, sand and gravel mixes, and gravel type soils meet or exceed this allowable bearing capacity. If there is question regarding the foundation bed allowable bearing capacity, a soils testing engineer should be consulted. Situations where the allowable bearing capacity is lower than this value will require special attention.

# NEW RECOMMENDED SLAB DESIGN FOR 2-POST LIFTS

FILE: MAN066

DATE: 2/98

REV DATE: 7/2003

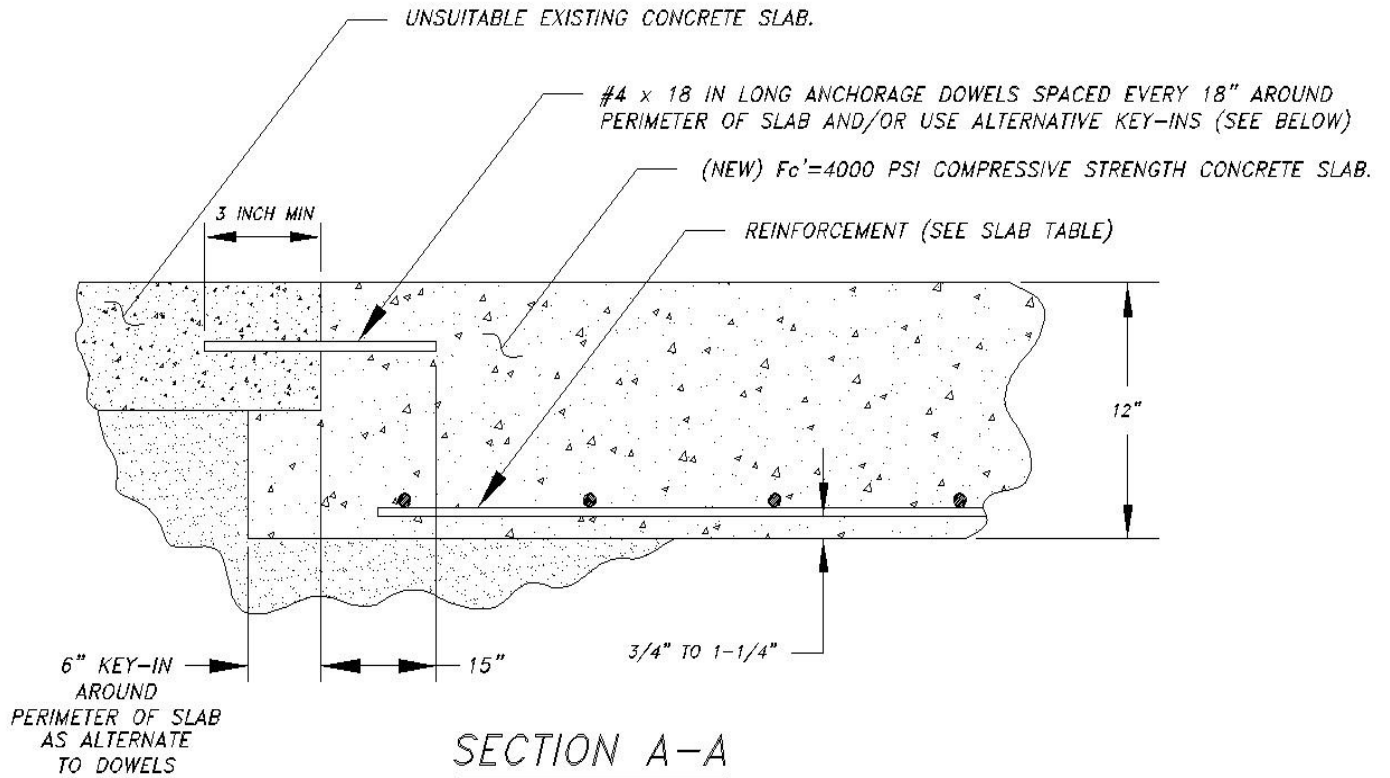
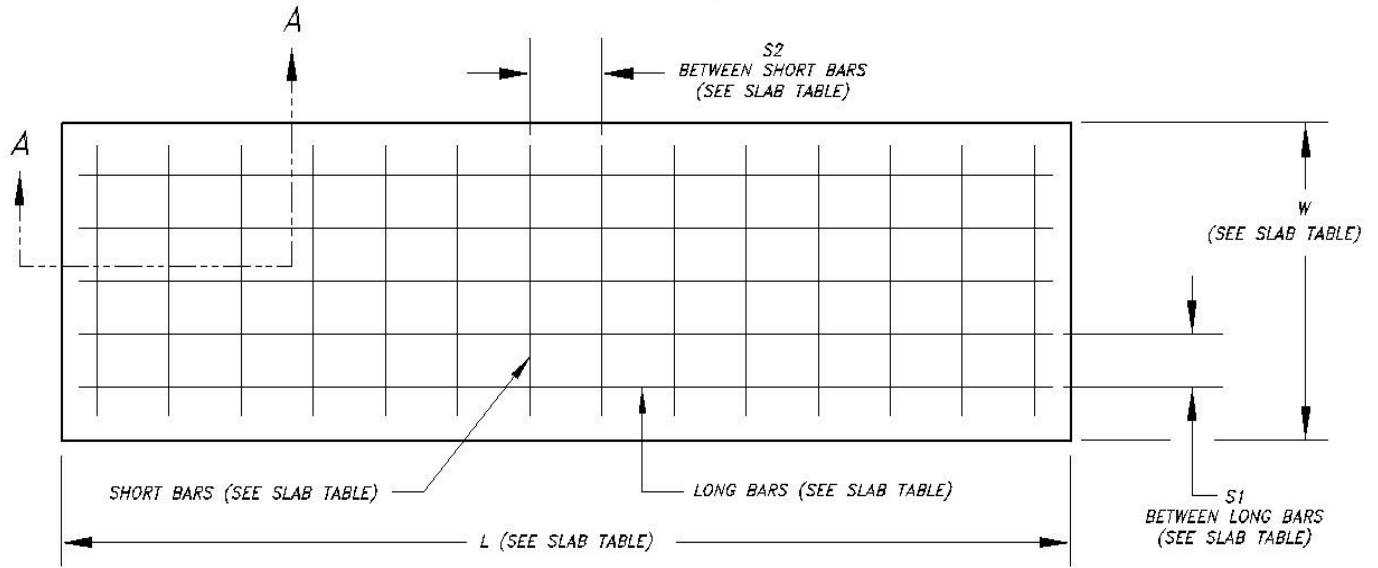

# NEW RECOMMENDED SLAB DESIGN FOR 4-POST LIFTS

FILE: MAN089  
DATE: 10/00  
REV DATE: 7/2003

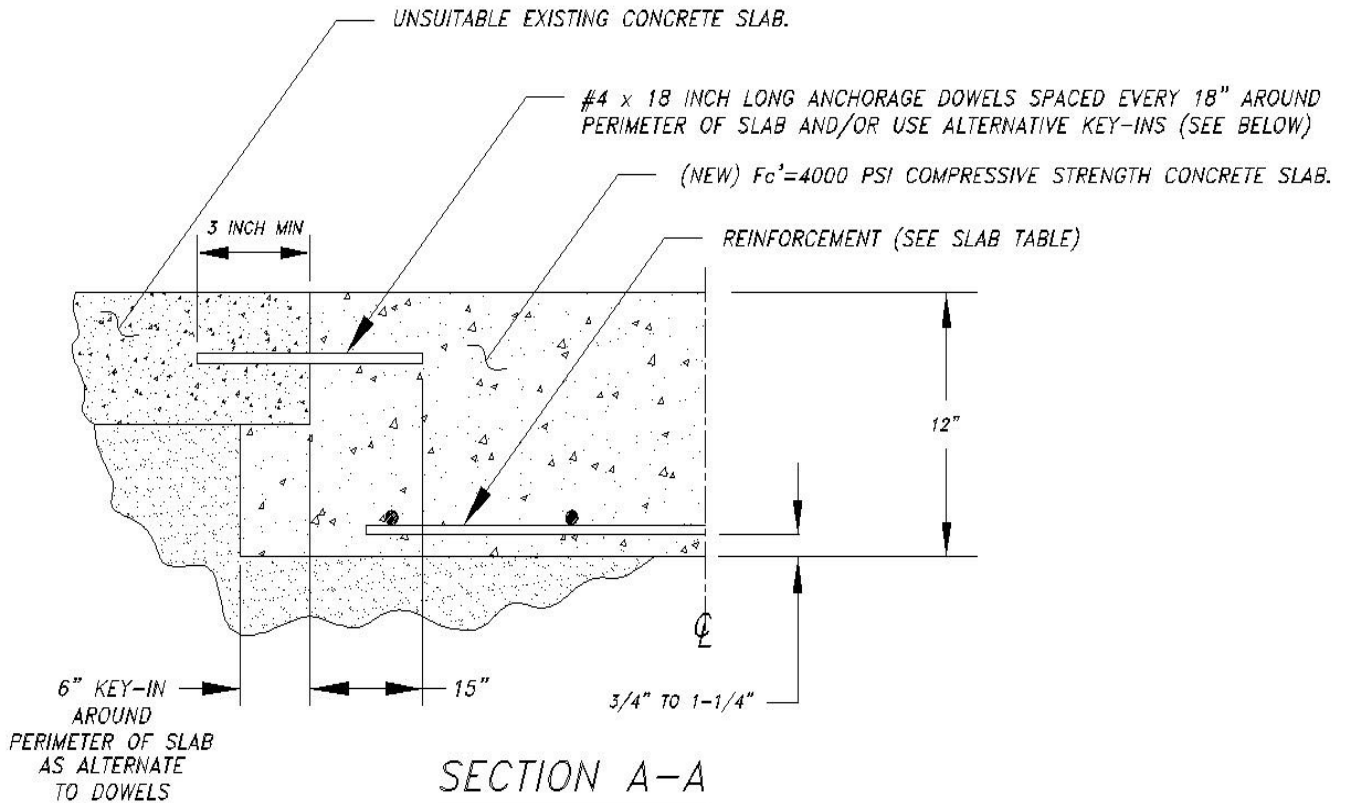
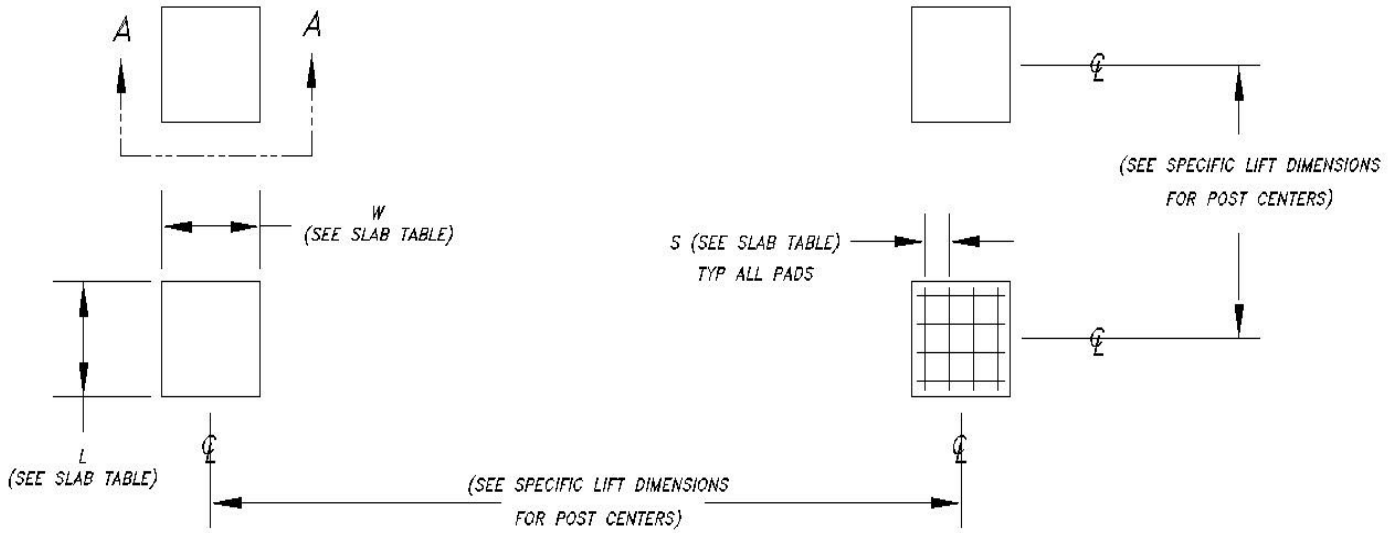

REV.	DESCRIPTION	DATE	BY	APP'D.
△				

TYPICAL BASE PLATE DETAIL  
(SYSTEM IA SHOWN BELOW - 8 ANCHORS PER BASE PLATE)

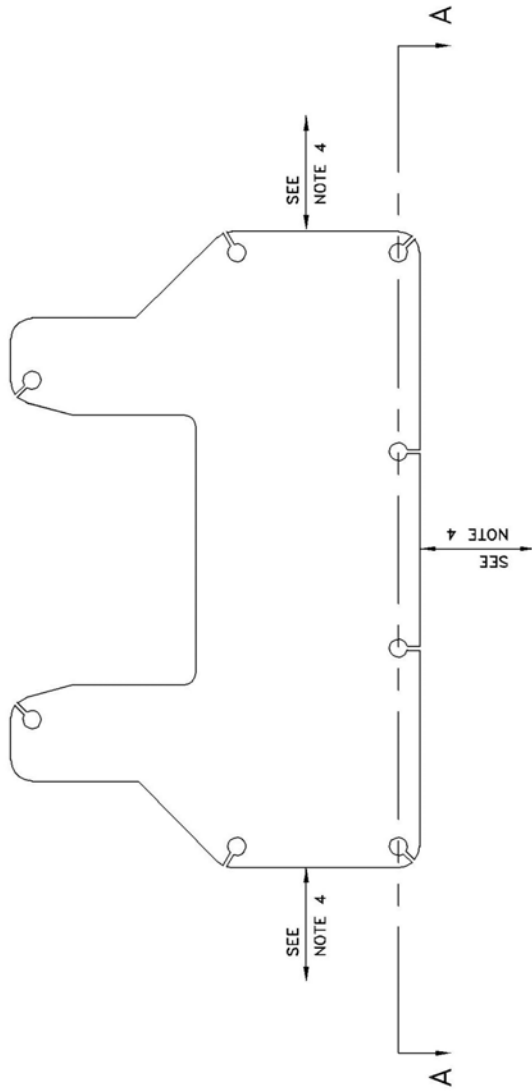

BASE PLATE ANCHORING INSTRUCTIONS:

1. LOCATE POSTS IN DESIRED LOCATION OF BAY, PER LIFT SETUP DIMENSIONS. REFER TO LIFT MANUAL FOR INSIDE DIMENSIONS OF COLUMNS, ETC.  
(FOR SYSTEM IA-10, THE INSIDE POST DIMENSION IS 120")
2. MATCH DRILL ALL BASE PLATE HOLES. REFER TO ANCHOR BOLT INSTALLATION SPECIFICATIONS ATTACHED FOR DRILL SIZE. (3/4" DIAMETER ORIGINAL WEJ-IT STYLE EXPANSION ANCHOR BOLTS).
3. INSTALL ANCHORS PER ANCHOR BOLT INSTALLATION SPECIFICATIONS ATTACHED. SHIM UNDER BASE PLATE AS NEEDED TO ENSURE THAT POSTS ARE SQUARE AND PLUMB (MAXIMUM OF 1/4") WITH COLORED SHIMS PROVIDED (HORSESHOE SHAPED).
4. ALL ANCHORS MUST BE A MINIMUM OF 6" AWAY FROM ANY EXPANSION SEAM, CONTROL JOINT, OR OTHER FLOOR INCONSISTENCIES.
5. DRILLING THRU ENTIRE SLAB THICKNESS IS PREFERRED WHEN POSSIBLE. THIS ALLOWS ANCHORS TO BE HAMMERED FLUSH TO CONCRETE IF LIFT IS RE-LOCATED.

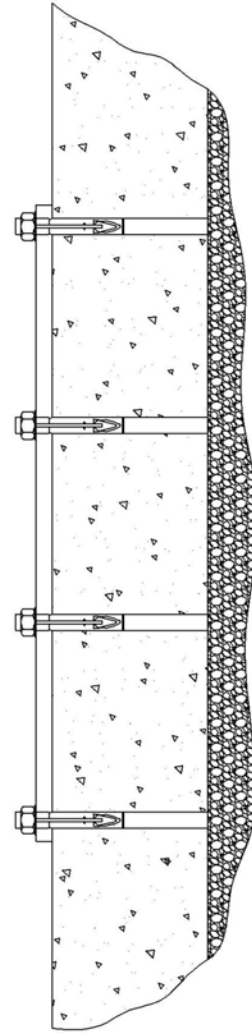

SECTION A-A:

C-SIZE

**NOTICE OF CONFIDENTIAL INFORMATION**











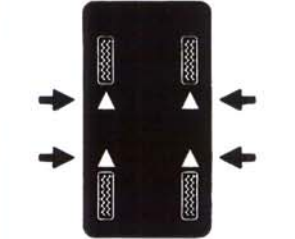

INFORMATION CONTAINED HEREIN IS CONFIDENTIAL AND PROPERTY OF MOHAWK RESOURCES LTD. IT SHALL BE USED SOLELY FOR PURPOSES OF INSPECTION, OR MAINTENANCE. THE INFORMATION SHALL NOT BE USED OR DISCLOSED BY THE RECIPIENT FOR ANY OTHER PURPOSES WHATSOEVER.

- NOTES:**
1. REMOVE ALL SHARP CORNERS & EDGES.
  2. UNLESS OTHERWISE SPECIFIED, SURFACE FINISH TO BE 125 RMS.
  3. WELDING MEDIUM SHALL CONFORM TO AWS SPECIFICATIONS TO E-70XX ELECTRODES OR E-70TT CODE 5.3 FLUX CORE WIRE ONLY.

TOLERANCES:	± .030
ANGULAR	± 1°
DECIMAL	± .005
DECIMAL	± .005
FILE NAME	ZZ912

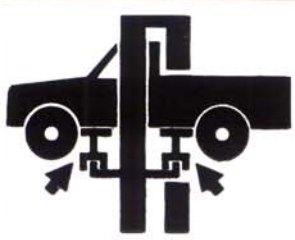
009-010-006	NEXT ASSEMBLY
-------------	---------------

SCALE	1/4	DRAWN	rww7089	<b>MOHAWK RESOURCES LTD.</b>
CHECKED	R.V.	APPROVED		TITLE
DATE	2/05	WEIGHT	N/A	FROM
		LB	N/A	DRAWING NUMBER
				ZZ912

<p><b>CAUTION</b></p>  <p>Lift to be used by trained operator only.</p>	<p><b>CAUTION</b></p>  <p>Authorized personnel only in lift area.</p>	<p><b>WARNING</b></p>  <p>Clear area if vehicle is in danger of falling.</p>	<p><b>WARNING</b></p>  <p>Position vehicle with center of gravity midway between adapters.</p>
<p><b>CAUTION</b></p>  <p>Use vehicle manufacturer's lift points.</p>	<p><b>CAUTION</b></p>  <p>Always use safety stands when removing or installing heavy components.</p>	<p><b>WARNING</b></p>  <p>Remain clear of lift when raising or lowering vehicle.</p>	<p><b>WARNING</b></p>  <p>Avoid excessive rocking of vehicle while on lift.</p>
<p><b>CAUTION</b></p>  <p>Use height extenders when necessary to ensure good contact.</p>	<p><b>CAUTION</b></p>  <p>Auxiliary adapters may reduce load capacity.</p>	<p><b>WARNING</b></p>  <p>Do not override self-closing lift controls.</p>	<p><b>WARNING</b></p>  <p>Keep feet clear of lift while lowering.</p>
<p>The messages and pictographs shown are generic in nature and are meant to generally represent hazards common to all automotive lifts regardless of specific style.</p> <p>Funding for the development and validation of these labels was provided by the Automotive Lift Institute, PO Box 33116 Indialantic, FL. 32903.</p> <p>They are protected by copyright. Set of labels may be obtained from ALI or its member companies.</p> <p>© 1992 by ALI, Inc. ALI/WL101c</p>		<p>The messages and pictographs shown are generic in nature and are meant to generally represent hazards common to all automotive lifts regardless of specific style.</p> <p>Funding for the development and validation of these labels was provided by the Automotive Lift Institute, PO Box 33116 Indialantic, FL. 32903.</p> <p>They are protected by copyright. Set of labels may be obtained from ALI or its member companies.</p> <p>© 1992 by ALI, Inc. ALI/WL101w</p>	

<p><b>SAFETY INSTRUCTIONS</b></p>  <p>Read operating and safety manuals before using lift.</p> <p>©</p>	<p><b>SAFETY INSTRUCTIONS</b></p>  <p>Proper maintenance and inspection is necessary for safe operation.</p> <p>©</p>
<p><b>SAFETY INSTRUCTIONS</b></p>  <p>Do not operate a damaged lift.</p> <p>©</p>	<p>The messages and pictographs shown are generic in nature and are meant to generally represent hazards common to all automotive lifts regardless of specific style</p> <p>Funding for the development and validation of these labels was provided by the Automotive Lift Institute, PO Box 33116 Indialantic, FL 32903</p> <p>They are protected by copyright Set of labels may be obtained from ALI or its member companies</p> <p>© 1992 by ALI, Inc ALI/WL101e</p>

# MOHAWK.

## Because Quality Lasts Forever.



### Model USL-6000

Full rise, space-saving, no-post, portable scissors lift, offers full under-car access.

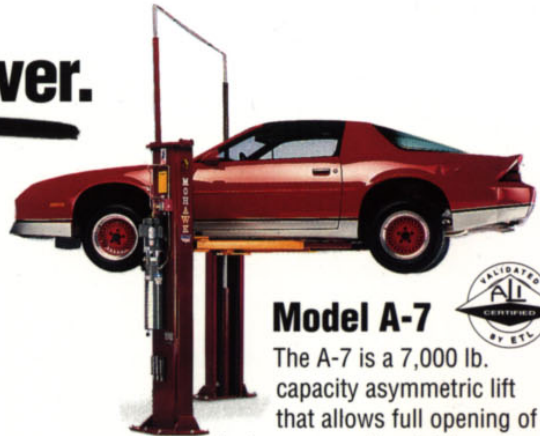

### Model A-7

The A-7 is a 7,000 lb. capacity asymmetric lift that allows full opening of all vehicle doors as well as total undercar/underdash access, thanks to Mohawk's unique "clear-floor" design. Low 4" arms accommodate all imports and low-riding sports cars. Includes both 3" and 6" truck adapters.



### Model System I

The 9,000 lb. capacity System I, like all Mohawk lifts, features Mohawk's patented hydraulic equalization system with adjustable overhead (or optional underground) hydraulic lines. Offers low 3 1/2" swing arms and comes standard with truck adapters.



### Model LMF-12, TP-15, TP-18, TP-26 & TP-30

These 12,000 to 30,000 lb. capacity models are the ideal heavy-duty lifts for up to Class VI trucks. Mohawk's unique "clear floor" design makes these the perfect lifts for all fleet applications. Truck adapters are standard equipment.



Model LMF-12

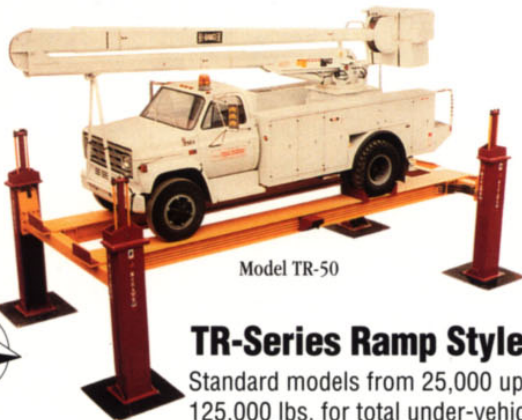

Model TR-50

### TR-Series Ramp Style Lifts

Standard models from 25,000 up to 125,000 lbs. for total under-vehicle access.

Ramp lengths from 20' to 50'. Completely operated by a single technician, and features fully interlocked, redundant safety systems.



# MOHAWK



Mohawk Industrial Park • P.O. Box 110  
Amsterdam, NY 12010  
1-800-833-2006 or 518-842-1431  
FAX 518-842-1289



[www.mohawklifts.com](http://www.mohawklifts.com)

# SEND US YOUR PHOTOS!

MOHAWK IS ALWAYS INTERESTED IN SEEING HOW YOUR LIFTS ARE USED. WE HAVE CREATED AN ON-LINE PHOTO DATABASE FOR CUSTOMERS TO VIEW OUR LIFTS IN USE.



VISIT [WWW.MOHAWKLIFTS.COM/PR/](http://WWW.MOHAWKLIFTS.COM/PR/) AND MAYBE WE CAN ADD YOUR PHOTOS TO OUR COLLECTION.  
(JPG FORMATS PREFERRED)

E-MAIL YOUR PHOTOS AND COMMENTS TO:  
[PHOTOS@MOHAWKLIFTS.COM](mailto:PHOTOS@MOHAWKLIFTS.COM)

BEST REGARDS & HAPPY LIFTING!

YOUR FRIENDS AT MOHAWK LIFTS